

DEPARTMENT OF THE ARMY TECHNICAL MANUAL

TEST SETS
TS-2/ TS-2A/TG TS-2B/TG
(TELETYPEWRITER SIGNAL DISTORTION)

This copy is a reprint which includes current pages from Changes 4-6

DEPARTMENT OF THE ARMY • JANUARY 1957

WARNING

DANGEROUS VOLTAGES EXIST IN THIS EQUIPMENT
Be careful when working on the 115-volt motor circuit.

DON'T TAKE CHANCES!

CHANGE
No. 4



HEADQUARTERS
DEPARTMENT OF THE ARMY
WASHINGTON, D.C., 21 April 1967

**TEST SETS TS-2/TG, TS-2A/TG, TS-2B/TG AND TS-2C/TG
(TELETYPEWRITER SIGNAL DISTORTION)**

TM 11-2208, 29 January 1957, is changed so that the manual also applies to:

Nomenclature	Order No.	Serial No.
Test Set TS-2C/TG	36222-Phila-57	1 through 331

Page 3. (As changed by C 3, 24 Sept 1963). Delete section I and substitute:

Section I. GENERAL

1. Scope

- a. This manual contains instructions for the operation, organizational, direct and general support, and -depot maintenance of Test Sets TS-2/TG, TS-2A/TG, TS/2B/TG and TS-2 TG. Also included is the functioning of the test sets.
- b. Basic nomenclature followed by (*) is used to indicate all models of the equipment covered in this manual. Thus Test Set TS/2(*)/TG refers to Test Sets TS-2/TG, TS-2A/TG, TS-2B/TG, and TS-2C/TG.

2. Index of Publications

Refer to the latest issue of DA Pam 310-4 to determine whether there are new editions, changes, or additional publications pertaining to the equipment. DA Pam 310-4 is an index of current technical manuals, technical bulletins, supply manuals (types 7, 8, and 9), supply bulletins, lubrication orders, and modification work orders that are available through publications supply channels. The index lists the individual parts (-10, -20, 35P, etc) and the latest changes to and revisions of each equipment publication.

3. Forms and Records

- a. Reports of Maintenance and Unsatisfactory Equipment. Use equipment forms and records in accordance with instructions in TM 38-750.
- b. Report of Damaged or Improper Shipment. Fill out and forward DD Form 6 (Report of Damaged or Improper Shipment) as prescribed in AR -700-58 (Army), NAVSANDA Publication 378 (Navy), and AFR 71-4 (Air Force).
- c. Reporting of Equipment Manual Improvements. Report of errors, omissions, and recommendations for improving this manual by the individual user is encouraged. Reports should be submitted on DA Form 2028 (Recommended Changes to DA Publications) and forwarded direct to Commanding General, U.S. Army Electronics Command, ATTN: AMSEL-MR-NMP-AD, Fort Monmouth N.J. 07703 Paragraph 4, last item. (As changed by C1, 14 Nov 1957). Delete the weight and substitute.

Weight (TS-2/TG, and TS-2B/TG). 70 pounds.

Weight (TS-2C/TG). 84 pounds.

*This change supersedes C 1, 14 November 1967; C 2, 15 January 1962; and C 3 24 September 1963.

Page 4, paragraph 5. (As changed by C1, 14 Nov 1957). Change the heading to: Description of Test Sets TS-2/TG, TS2A/TG, and TS-2B/TG.

(As added by C1, 14 Nov 1957). Add paragraph 5.1 after paragraph 5:

5.1 Description, Test Set TS-2C/TG
(fig. 2.1)

Test Set TS-2C/TG is similar in appearance and construction to Test Sets TS-2TG, TS-2A/TG, and TS-2B/TG, except that its overall dimensions are slightly larger (25 inches long, 17 inches high, and 16 inches deep), and its weighs more (84 pounds). The operating components of the test set are completely enclosed in an aluminum radiation cover which is housed within a wooden cover. All operating controls are located on the radiation cover. All connections to the controls are made with a cable and multipin connector located inside the radiation cover.

(As added by C1, 14 Nov 1957). Add figure 2.1 after figure 2:

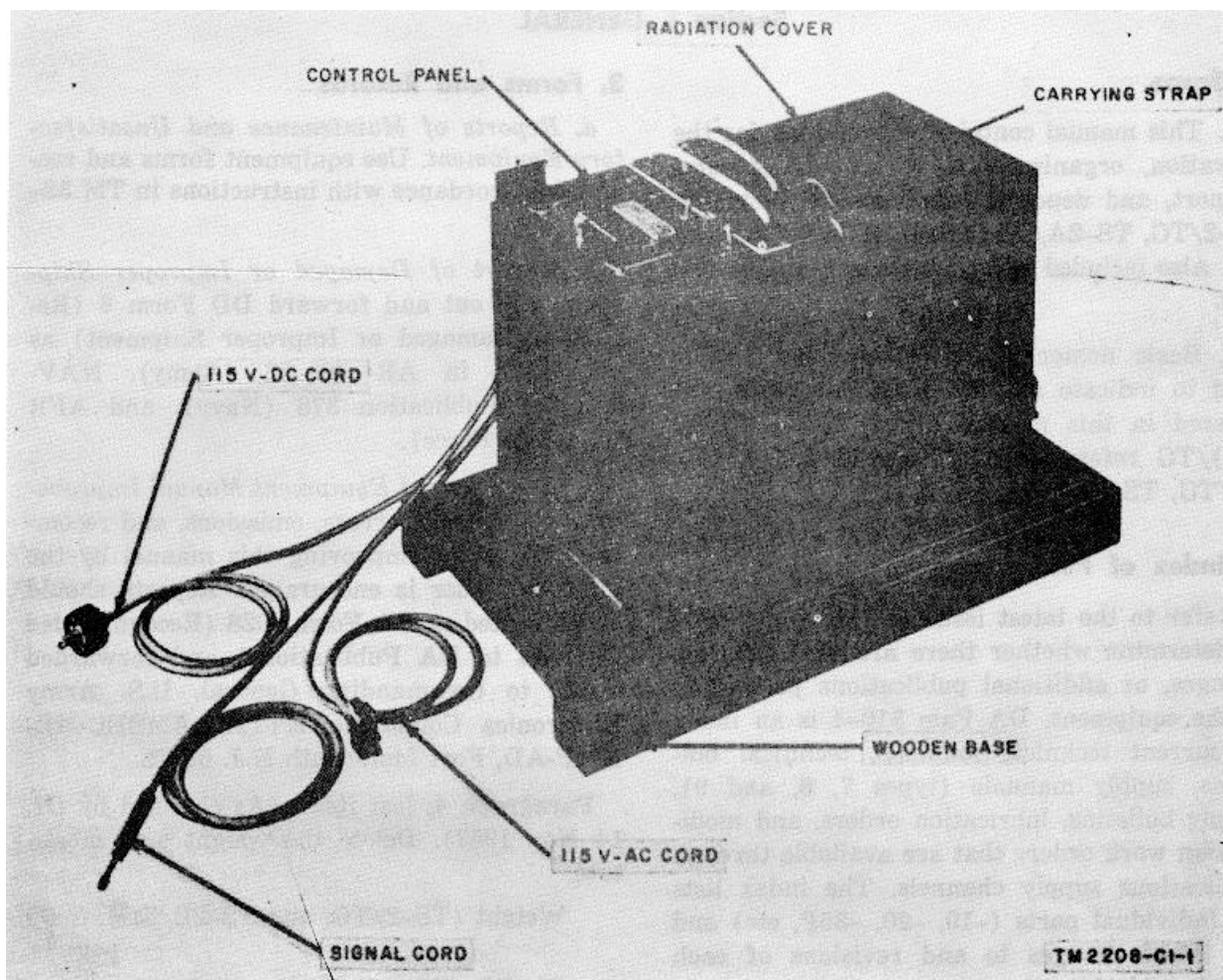

Figure 2.1. Test Set TS-2C/TG, wooden cover removed.

Page 5, paragraph 6. (As changed by C1, 14 Nov 1967). Make the following changes in the table: TS-2/TG column, line 3. Change "2-500-ohm" to Two 500-ohm.

Add the following column:

TS-2C/TG
Same as TS-2B/TG, Orders No. 25796-Phila-54, No. 31154-Phila-55, No. 15598-Phila-55. One 250-ohm resistor.
Same as TS-2B/TG, Orders No. 25796-Phila-54, No. 31154-Phila-55, and No. 15598-Phila-55.
TS-2C/TG
This resistor now mounted on switch S1 bracket on the base casting.
Same as TS-2B/TG, Orders No. 25796-Phila-54, No. 31154-Phila-55, and No. 15598-Phila-55.
Not used.
Control panel is part of radiation cover with control markings placed on bakelite strip which is secured by screws to the cover.
Sealed bearing to fit new motor which requires no further lubrication.
Relocated within radiation cover.
Same as TS-2B/TG.

Add after the last item:

Item	TS-2/TG	TS-2A/TG	TS-B/TG	TS2B/TG Orders No. 25796- Phila-54. No. 31154-Phila 55 and No. 15598-Phila 55	TS-2C/TG
Radiation cover	None-----	None-----	None-----	None-----	Aluminum cover which completely encloses operating components on base casting
Radio interference suppression circuits.	On base casting	Same as TS-2/TG	Same as TS-2/TG	Same as TS-2/TG	Improved suppression components located within shielded chassis in top of radiation cover.
Cable harness	None-----	None-----	None-----	None-----	A cable harness, and multipin connector between test set and radiation cover.
Spare distributor brushes	Two sets-----	Same as TS-2/TG.	Same as TS-2/TG.	Same as TS-2/TG	Three sets
DC OUT IN SWITCH.	None-----	None-----	None-----	None -----	Located on control panel
Alternate speed gears	Available through supply channels.	Same as TS-2/TG.	Same as TS-2/TG.	Same as TS-2/TG.	Stored in radiation cover.
FILTER OUT FILTER IN switch.	On base casting	Same as TS-2/TG.	Same as TS-2/TG.	Same as TS-2/TG.	None
LOCAL TEST JACKS.	On control panel above motor assembly..	Same as TS-2/TG.	Same as TS-2/TG.	Same as TS-2/TG	Replaced by MAINTENANCE TEST JACK and LOCAL TEST JACK mounted on radiation cover.
Location of controls.	On control panel above motor assembly.	Same as TS-2/TG.	Same as TS-2/TG.	Same as TS-2/TG.	On radiation cover.
Location of target lamp switch.	Underneath control panel.	Same as TS-2/TG.	Same as TS-2/TG.	Same as TS-2/TG.	On target lamp mounting bracket.
Location of target lamp	At front of base casting.	Same as TS-2/TG.	Same as TS-2/TG.	Same as TS-2/TG.	On left side of base casting.

Item	TS-2/TG	TS-2A/TG	TS-B/TG	TS2B/TG Orders No. 25796- Phila-54. No. 31154-Phila 55 and No. 15598-Phila 55	TS-2C/TG
Location of spare parts box.	On wooden base	Same as TS-2/TG.	Same as TS-2/TG.	Same as TS-2/TG	On base plate.
Location of carrying strap.	On control panel within wooden cover.	Same as TS-2/TG.	Same as TS-2/TG.	Same as TS-2/TG.	On radiation cover.
Motor fuse-----	1.6-ampere, plug type, mounted on base casting.	Same as TS-2/TG.	Same as TS-2/TG.	Same as TS-2/TG.	1.0-ampere, cartridge type, mounted on top of radiation cover.

Page 6. (As changed by C3, 24 Sept 1963). Delete paragraph 9 and substitute.

9. Checking Unpacked Equipment

a. Inspect the equipment for damage incurred during shipment. If the equipment has been damaged, report the damage on DD Form 6 (para 2).

b. See that the equipment is complete as listed on the packing slip. If a packing slip is not available, check the equipment against the basic issue items list (app II). Report all discrepancies in accordance with TM 3-750. Shortage of a minor assembly or part that does not affect proper functioning of the equipment should not prevent use of the equipment.

c. If the equipment has been used or reconditioned, see whether it has been changed by a modification work order (MWO). If the equipment has been modified, the MWO number will appear on the front panel near the nomenclature plate. Check to see whether the MWO number (if any) and appropriate notations concerning the modification have been entered in the manual.

Note. Current MWO's applicable to the equipment are listed in DA Pam 310-4.

Page 8. (As changed by C1, 14 Nov 1957). Delete paragraph 10 and substitute:

10. Fuse Check

Check the motor fuse before applying power to the unit. In the TS-2/TG, TS-2A/TG, and TS-2B/TG, this fuse is a plug-type fuse, rated at 1.6 amperes, 125 volts. It is located in the base casting. In the TS-2C/TG, this fuse is a 4 cartridge type fuse, rated at 1.0 amperes, 125 volts. It is located on the top of the radiation cover.

(As added by C1, 14 Nov 1957). Insert figures 4.1 and 4.2 after figure 4.

Page 9, paragraph 12. (As changed by C1, 14 Nov 57).

Subparagraph c. Delete the first sentence and substitute:

c. Open the door on the control panel of the TS-2/TG, TS-2A/TG, and TS-2B/TG (fig. 4). Unlatch the radiation cover of the TS-2C/TG and tilt it back on its hinge (fig. 4.2). Turn on the target lamp and adjust the motor speed as follows:

Subparagraph c(3). Delete the first sentence and substitute: On the TS-2/TG, TS-2A/TG, and TS-2B/TG, if the motor speed is too fast, stop the motor and, if necessary rotate the governor until the speed adjusting wheel is in its highest position above the armature shaft.

Subparagraph c(3). Add subparagraph 3.1 after subparagraph (3):

(3.1) On Test Set TS-2C/TG, if the motor speed is too fast, press the governor control bracket (fig. 4.2) mounted on the base casting until it makes contact with the governor adjusting wheel. Maintain this contact until the motor reaches proper speed.

Subparagraph c(4). Delete the first sentence and substitute:

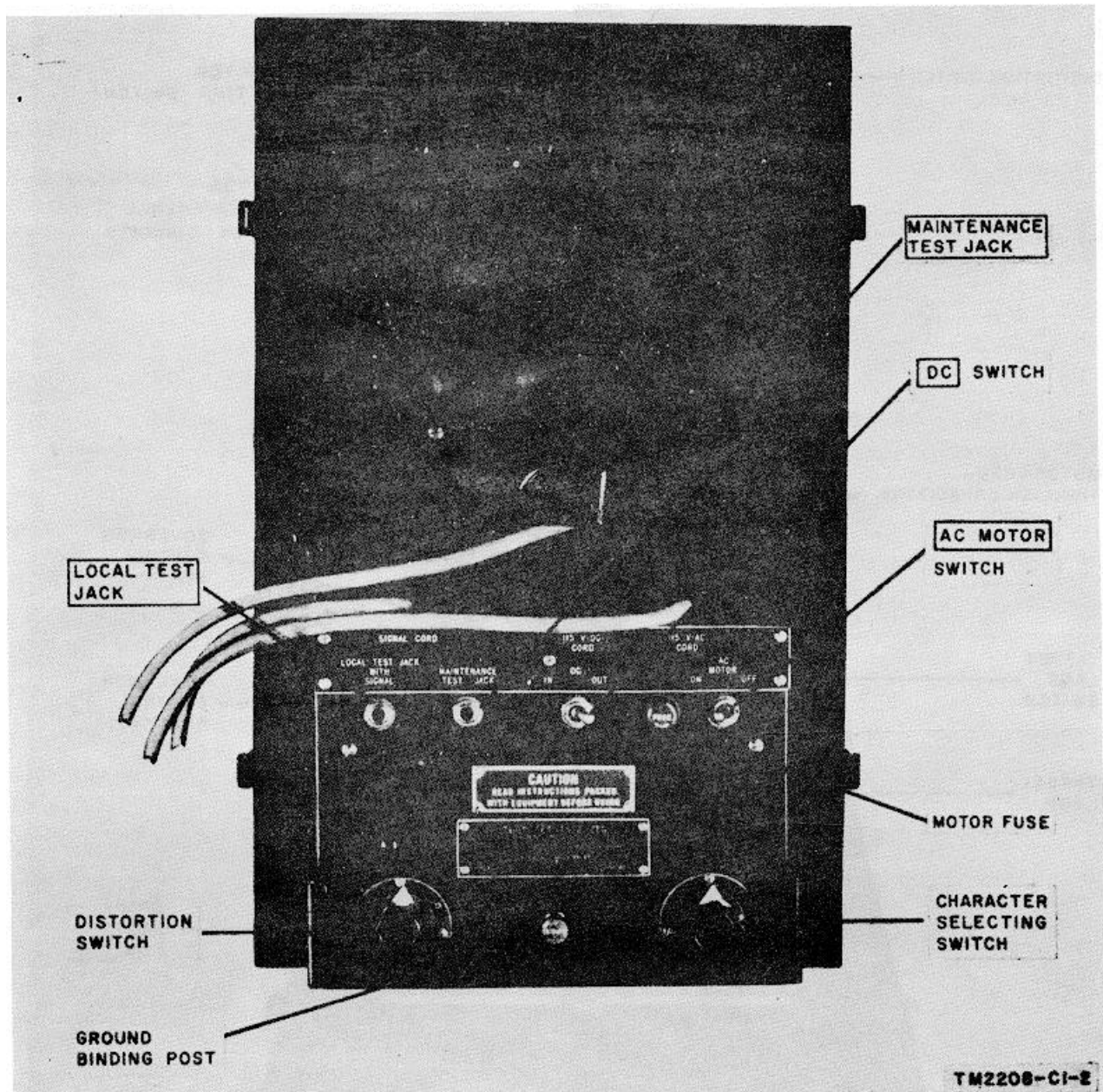

Figure 4.1. Test Set TS-2C/TG showing radiation cover controls

On the TS-2/TG, TS-2A/TG, and TS-2B/TG, if the motor speed is too slow, follow the procedure given in (3) above, except that the speed adjusting wheel should be turned clockwise about one-fourth turn. Add subparagraph (4.1) after subparagraph (4):

- (4.1) On Test Set TS-2C/TG, if the motor speed is too slow, press the governor control arm (fig. 4.2) mounted on the motor frame until it makes contact with the governor adjusting wheel. Maintain this contact until the motor reaches proper speed.

Page 10, paragraph 15a(11), line 8. (As added by C1, 14 Nov 1957). After "55", add: and on Test Set TS-2C/TG.

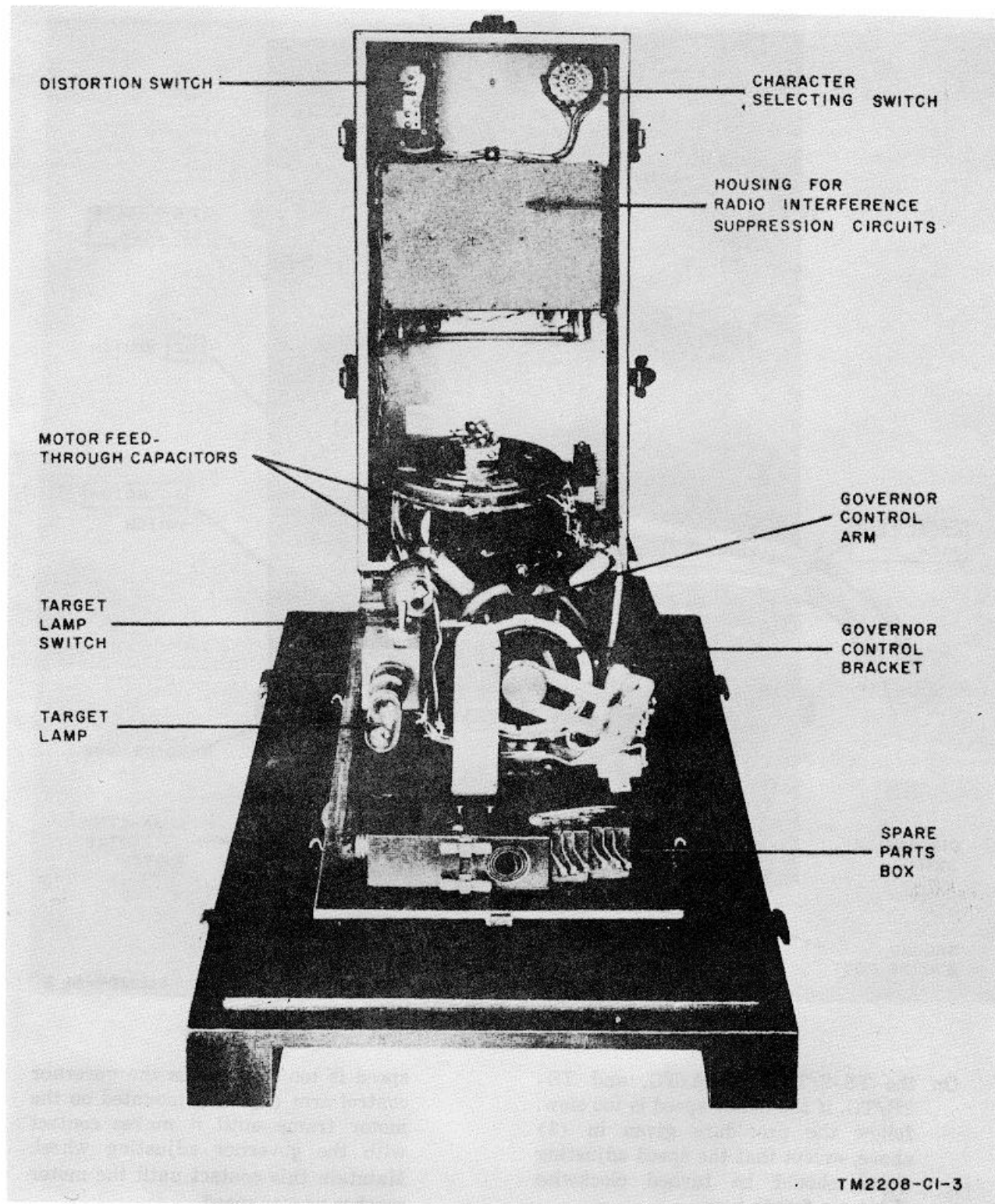

Figure 4.2. Test Set TS-2C/TG, with radiation cover open.

Page 12, paragraph 15. (As changed by C1, 14 Nov 1957).

Subparagraph d(7). Delete and substitute: (7) On the TS-2/TG, TS-2A/TG, and

TS-2B/TG, turn the filter switch on the test set to the FILTER OUT position. Right hand column, top three lines. Delete and substitute:

- (10) Plug the ac power cord of the test set into a suitable source of ac. (The dc power cord is not used for this test).

Subparagraph e(3). Delete and substitute:

- (3) On the TS-2/TG, TS-2A/TG, and TS-2B/TG, turn the filter switch on the test set to the FILTER OUT position.

Page 13 paragraph 16. (As changed by C1, 14 Nov 1957). At the end of the last sentence, add: for use with the TS-2/TG, TS-2A/TG, and TS-2B/TG.

After the last sentence add: On Test Set TS-2C/TG, these gears (motor pinion and main shaft) are located in the top of the radiation cover (fig. 21.2).

Note. To avoid confusion when changing gears on the TS-2C/TG, remove the gears in use from the test set and place them in their proper storing location before removing the gears for the new speed. The labels above each mounting stud identify the gears for each speed and give the number of teeth per gear.

Page 14, paragraph 18. (As added by C1, 14 Nov 1957). After the heading, add: (TS-2/TG, TS-2A/TG, and TS-2B/TG). Add paragraph 18.1 after paragraph 18.

18.1. Controls (TS-2C/TG) (fig. 4.1)

The controls of the TS-2C/TG are the same as those of the TS-2/TG, TS-2A/TG, and TS-2B/TG, except as follows:

- a. The FILTER OUT FILTER IN switch is not included.
- b. The DC IN-OUT switch is added (d below).
- c. The LOCAL TEST JACKS are replaced by a MAINTENANCE TEST JACK and one LOCAL TEST JACK (d below).
- d. The functions of the new controls follow:

Paragraph 19. (As added by C1, 14 Nov 1957). Add after subparagraph b:

Control	Function
DC IN-OUT switch	Applies dc to the signal circuits.
LOCAL TEST JACK	Provides a means of monitoring the signal sent to the line after radio interference suppression filtering (formerly one of the LOCAL TEST JACKS).
MAINTENANCE TEST JACK.	Provides a means of monitoring the signal sent to the line without radio interference suppression filtering (formerly one of the LOCAL TEST JACKS).

- b.1. On the TS-2C/TG, release the five spring-loaded catches which secure the radiation cover to the base casting and tilt the cover on its hinge.

Page 17, chapter 4. (As changed by C3, 24 Sept 1963). Add the following note below the chapter heading.

Note. Organizational maintenance is not authorized for this equipment. Delete section and substitute:

SECTION I. PREVENTATIVE MAINTENANCE CHECKS AND SERVICES

28. Scope of Operator's Maintenance

The maintenance duties assigned to the operator of Test Sets TS-2(*)/TG are listed below together with a reference to the paragraphs covering the specific maintenance function. The duties assigned do not require tools or test equipment.

- a. Operator's daily preventive maintenance checks and services (para 31).
- b. Operator's weekly preventive maintenance checks and services (para 32).
- c. Cleaning (para 33).

29. Preventive Maintenance

Preventive maintenance is the systematic care, servicing, and inspection of equipment to prevent the occurrence of trouble, to reduce downtime, and to assure that the equipment is serviceable.

a. Systematic Care. The procedures given in paragraphs 31 through 33 cover routine systematic care and cleaning essential to proper upkeep and operation of the equipment.

b. Preventive Maintenance Checks and Services. The preventive maintenance checks and services charts (paras 31 and 32) outline functions to be performed at specific intervals. These checks and services are to maintain Army electronic equipment in a combat serviceable condition; that is, in good general (physical) condition and in good operating condition. To assist operators in maintaining combat serviceability, the chart indicates what to check, how to check, and what the normal conditions are. The References column lists the illustrations, paragraphs, or manuals that contain supplementary information. If the defect cannot be remedied by the operator, higher category maintenance or repair is required. Records and reports of these checks and services must be made in accordance with the requirements set forth in TM 38-750.

30. Preventive Maintenance Checks and Services Periods

Preventive maintenance checks and services of the TS-2(*)/TG are required on a daily and weekly basis.

a. Paragraph 31 specifies checks and services that must be accomplished daily and under the special conditions listed below.

- (1) When the equipment is initially installed.
- (2) When the equipment is reinstalled after removal for any reason.
- (3) Before the equipment is placed in storage.
- (4) When the equipment is removed from storage.
- (5) At least once each week if the equipment is maintained in standby condition.

b. Paragraph 32 specifies additional checks and services that must be performed once each week.

31. Operator's Daily Preventive Maintenance Checks and Services Chart

Sequence No.	Item to be inspected	Procedure	References
1	Control panel, radiation cover(TS-2C/TG), and wooden cover (TS-2/TG, TS-2A/TG, and TS-2B/TG).	Clean the exterior surfaces of the control panel, the radiation cover (TS-2C/TG), and the wooden cover (TS-2/TG, TS-2A/TG, and TS-2B/TG).	Para 33.
2	Switches and knobs	Operate each knob and switch several times. Observe that the mechanical action of each knob and switch is smooth and free of external and internal binding.	Fig. 4 and 4.1.
3	Target lamp	Open the door on the control panel of the TS-2/TG, TS-2A/TG, and TS-2B/TG (fig. 4). Unlatch the radiation cover of the TS-2C/TG and tilt it back on its hinge (fig. 4.2). Operate the target lamp switch to the on position. The target lamp should light.	
4	Motor speed	Check, and if necessary, adjust the motor speed	Para 12.

32. Operator's Weekly Preventive Maintenance Checks and Services Charts

Sequence No.	Item to be inspected	Procedure	References
1	Wooden cover and wooden base.	Check the cover for gouges, nicks, splintering, and cracks. Check the latches for distortion, looseness, or other damage. Check the hinged lid for secure	Para 33 and fig. 1

32. Operator's Weekly Preventive Maintenance Checks and Services Charts

Sequence No.	Item to be inspected	Procedure	References
		mounting and proper fit. Check the carrying handles; they should be firmly mounted anti should be bent or otherwise (damage (or distorted. Check for (anti tighten) loose screws on the, wooden cover. Clean the exterior surfaces of the cover of dirt dust, grime, and grease. Remove the wooden cover from the woolen base. Check the base for (and tighten) loose screws. Clean the interior of the wooden cover and the wooden base.	
2	Canvas	Check the canvas carrying strap for secure mounting, and for rotting, tears, mildew, or other damage.	Figs. 4 and 4.1.
3	Radiation cover (TS2C/TG only).	Check for bare spots, rust, anti corrosion. Examine the latches; look for broken springs, bent or distorted catches. Tighten loose screws.	Fig. 2.1.
4	Signal, ac, anti dc cords	Inspect all cords for cuts, breaks, fraying, kinks, deterioration, and strains.	Figs. 2 and 2.1.
5	Plugs and jacks	Check the plugs and jack for loose connections, damaged, bent, or corroded connectors.	
6	Fuses	See that operating fuses are of the correct value. Check spare fuses for proper value and quantity	Para 10 anti app III.
7	Ground binding posts (TS-2C/TG only).	Check for film mounting and damaged threads	Fig. 4.1.
8	Nuts, bolts, screws	Check for loose or missing nuts, bolts, and screws on the control panel of the TS-2/TG, TS-2A/TG, and TS-2B/TG; on the radiation cover of the TS-2C/TG.	Figs. 4 and 4.1.
9	Operating check	If a teletypewriter is available, make an operating check of the TS-2(*)/TG.	Para 17 through 21.
10	Completeness	See that the equipment is complete	App III.
11	Publications	See that all publications are complete, serviceable and current.	DA Pam 3104.
12	Modification	Check DA Pam 310-4 to determine if new applicable MWO's have been published. All urgent MWO's must be applied immediately. All NORMAL. MWO's must be scheduled.	TM 38-750 and DA Pam 310-4.
13	Spare parts	Check all spare parts (operator) for general condition and method of storage. There should be no evidence of overstock, and all shortages must be on valid requisitions.	App III.

33. Cleaning

Inspect the exterior of the test sets including the radiation cover. The exterior surfaces should be clean, and free of dust, dirt, grease, and fungus.

- a. Remove dust and loose dirt with a clean soft cloth.

Warning: Cleaning compound is flammable and its fumes are toxic. Provide adequate ventilation. Do not use near a flame.

- b. Remove grease, fungus, and ground in dirt from the covers; use a cloth dampened (not wet) with cleaning compound (FSN 7930395-9542).

- c. Remove dust or dirt from plugs and jacks with a brush.

d. Clean the control panels and control knobs; use a soft clean cloth. If dirt is difficult to remove, dampen the cloth with water; mild soap may be used for more effective cleaning.

Page 21. (As changed by C3, 24 September 1963). Delete section II and renumber section III as section II.

Page 25, paragraph 5Mb, line 2. (As changed by C1, 14 Nov 1957). Change friction tight to: friction tight.

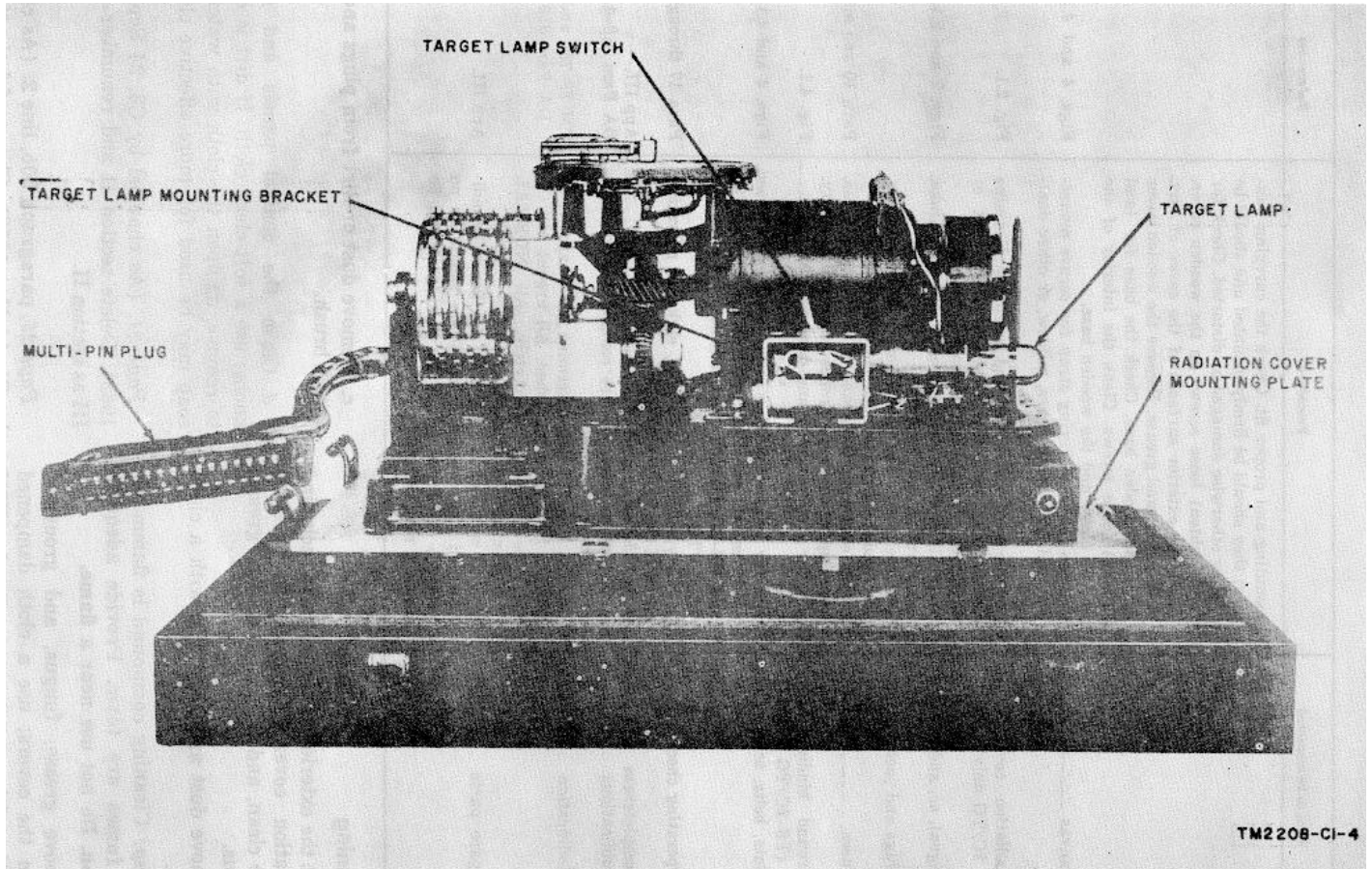

Figure 21.1. Test Set TS-2C/TG, without radiation cover (target lamp side).

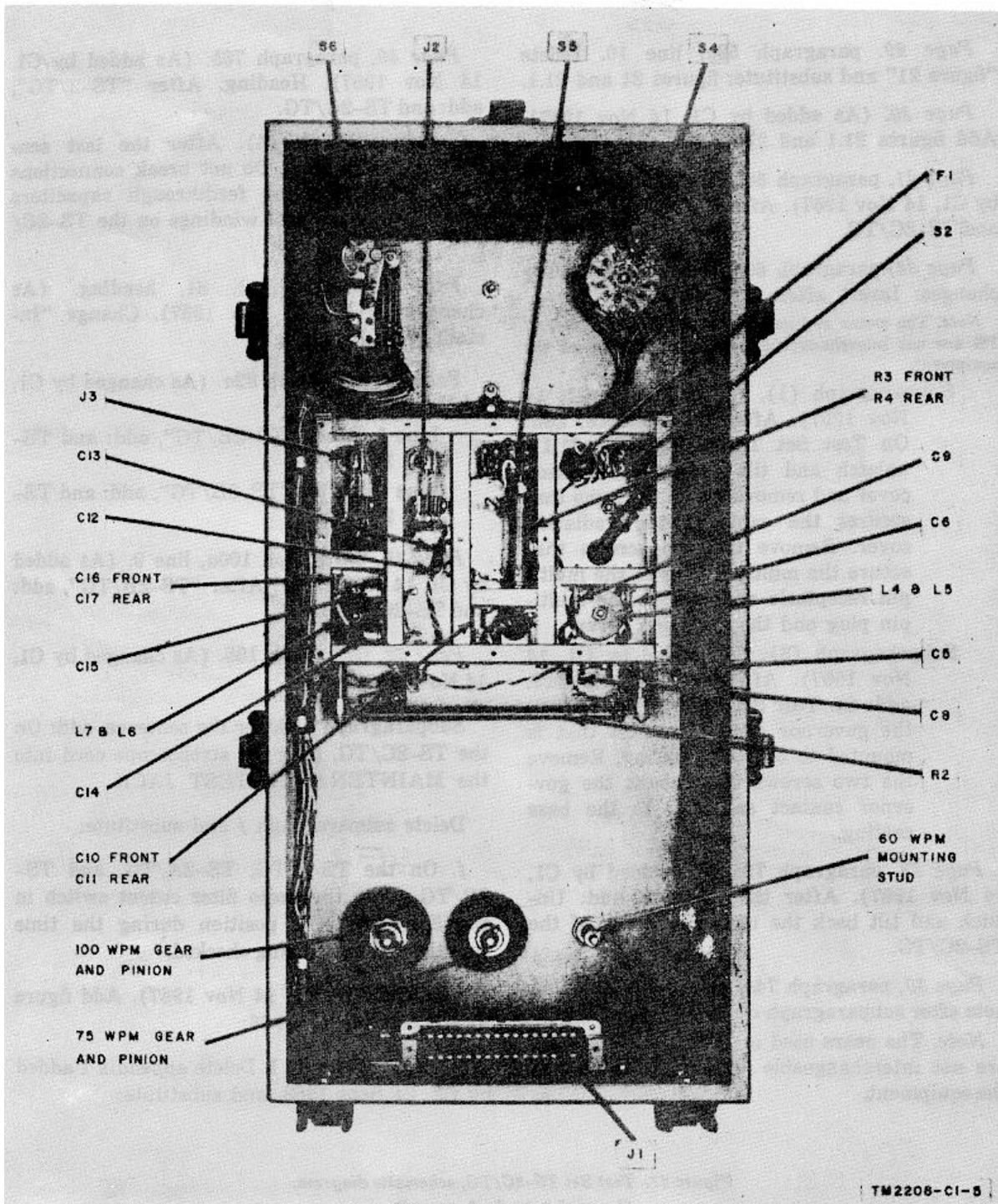

Figure 21.2. Test Set TS-2C/TG, showing radiation interference suppression circuit components.

Page 27. (As added by C1, 14 Nov 1957). Add the following note below the headings of paragraphs 55, 56, and 57:

Note. On Test Set TS-2C/TG, the distortion switch must be removed from the radiation cover before making this adjustment.

Page 29. paragraph 599a, line 10. Delete "figure 21" and substitute: figures 2.1 and 21.1.

Page 30. (As added by C1, 14 Nov 1957). Add figures 21.1 and 21.2 after figure 21:

Page 31. paragraph 60c, line 1. (As changed by C1, 14 Nov 1957). After "TS-2B/TG", add: and TS-2C/TG.

Page 38. paragraph 69a, make the following changes: Insert after first sentence:

Note. The motor and gears used in Test Set TS-2A/TG are not interchangeable with other models of the equipment.

Subparagraph (1). (As added by C1, 14 Nov 1957). After the sentence, add: On Test Set TS-2C/TG (fig. 21.1), unlatch and tilt back the radiation cover and remove the cable clamp that secures the cable to the radiation cover. Remove the two screws that secure the multipin plug to the multipin receptacle and remove the multipin plug and the radiation cover.

Subparagraph (3).. (As added by C1, 14 Nov 1957). After the last sentence, add: On Test Set TS-2C/TG, remove the governor control bracket that is mounted to the base casting. Remove the two screws that mount the governor contact assembly to the base casting.

Page 38, paragraph 72a, (As added by C1, 14 Nov 1957). After the sentence, add: Unlatch and tilt back the radiation cover of the TS-2C/TG.

Page 39, paragraph 74c. Insert the following note after subparagraph c:

Note. The gears used in Test Set TS-2A/TG are not interchangeable with other models of the equipment.

Page 40, paragraph 76b. (As added by C1: 14 Nov 1957). Heading. After "TS-2/TG", add: and TS-2C/TG.

Subparagraph (4). After the last sentence, add: Do not break connections between the feedthrough capacitors and the field windings on the TS-2C/ TG.

Page 41, paragraph 81, heading. (As changed by C1, 14 Nov 1957). Change "Installing" to: Installing.

Page 42, paragraph 82a. (As changed by C1, 14 Nov 1957).

Line 5. After "TS-2B/TG", add: and TS-2C/TG.

Line 15. After "TS-2B/TG", add: and TS-2C/TG.

Page 49, paragraph 100a, line 9. (As added by C1, 14 Nov 1957). After "TS-2B/TG", add: and TS-2C/TG.

Page 52, paragraph 105. (As changed by C1, 14 Nov 1957).

Subparagraph b. After the sentence, add: On the TS-2C/TG, plug the stroboscope cord into the MAINTENANCE TEST JACK.

Delete subparagraph f and substitute:

f. On the TS-2/TG, TS-2A/TG, and TS-2B/TG, place the radio filter cutout switch in the FILTER OUT position during the time that the test set is being checked.

(As added by C1, 14 Nov 1957). Add figure 37 and 38 after figure 36:

Page 54, appendix I. Delete appendix I added by C3, 24 Sept 1963, and substitute:

Figure 37. Test Set TS-2C/TG, schematic diagram.
(Located in back of manual)

Figure 38. Test Set TS-2C/TG, wiring diagram.
(Located in back of manual)

**APPENDIX A
REFERENCES**

The following applicable references are available to the operator of the TS-2(*)/TG.

DA Pam 310-4	Index of Technical Manuals, Technical Bulletins, Supply Manuals (Types 7, 8, and 9), Supply Bulletins, Lubrication Orders, and Modification Work Orders.
TB SIG 364	Field Instructions for Painting and Preserving Electronics Command Equipment.
TM 9-213	Painting Instructions for Field Use.
TM 11-2217	Distortion Test Sets TS383/GG, TS-383A/GG, and TS-383B/GG.
TM 11-5500	Multimeter TS-297/U.
TM 11-6625-364-12	Organizational Maintenance Manual: Distortion Test Sets TS-383/GG, TS383A/GG, and TS383B/GG.
TM 38-750	Army Equipment Record Procedures.

Delete appendix II and III, changed by C3,24 Sept 1963, and substitute:

**APPENDIX B
BASIC ISSUE ITEMS
Section I. INTRODUCTION**

B-1. General

This appendix lists items for Test Sets, Teletypewriter TS-2/TG, TS-2A/TG, TS-2B/TG, and TS-2C/TG, the component items comprising it, and the items which accompany it, or are required for installation, operation, or operator's maintenance.

B-2. Explanation of Columns

An explanation of the columns in section II is given below.

a. Source, Maintenance, and Recoverability Codes, Column 1.

- (1) Source code, column 1a. The selection status and source for the listed item is noted here. The source code used is:

Code	Explanation
P	Applies to repair parts which are stocked in or supplied from the GSA/DSA, or Army supply system, and authorized for use at indicated maintenance categories.

- (2) Maintenance code, column 1b. The lowest category of maintenance authorized to install the listed item is noted here. The maintenance code, used is as follows:

Code	Explanation
O	Organizational maintenance
H	General support maintenance

- (3) Recoverability code, column 1c. Not used.
Note. When no code is indicated in the recoverability column, the part will be considered expendable.

- b. Federal Stock Number, Column 2. The Federal stock number for the item is indicated in this column.
c. Description, Column S. The Federal item name, a five digit manufacturer's code, part number, and when required, the model designator (*), which indicates different models of the end equipment, are included in this column.
d. Unit of Issue, Column 4. The unit used as a basis of issue (e.g. ea, pr, ft, yd, etc) is noted in this column.

- e. Quantity Incorporated in Unit Pack, Column 5. Not used.
- f. Quantity Incorporated in Unit, Column 6. The total quantity of the item used in the equipment is given in this column.
- g. Quantity Authorized, Column 7. The total quantity of an item required to be on hand and necessary for the operation and maintenance of the equipment is given in this column.
- h. Illustration, Column 8.
 - (1) Figure number, column 8a. The number of the illustration in which the item is shown is indicated in this column.
 - (2) Item or symbol number, column 8b. The call out number used to reference the item in the illustration appears in this column.

B-3. Federal Supply Codes

This paragraph lists the Federal supply code with the associated manufacturer's name.

Code	Manufacturer
08806	General Electric Co. Miniature Lamp Dept
71400	Bussmann Mfg Division of McGraw-Edison Co.
80063	Army Electronic Command Procurement and Production Directorate

SECTION II. BASIC ISSUE ITEMS LIST

(1)			BASIC ISSUE ITEMS LIST						(4)	(5)	(6)	(7)	(8)		
SOURCE CD	MAINT. CD	REC. CODE	(2) FEDERAL STOCK NUMBER	(3) DESCRIPTION						UNIT OF ISSUE	QTY INC IN UNIT PACK	QTY INC IN UNIT	QTY AUTH	(8)	
				MODEL										(A) FIGURE NUMBER	(B) ITEM OR SYMBOL NUMBER
				1	2	3	4	5	6						
			6625-243-5173									1			
				*	*	*	*					1			
P	O		5920-232-3683				*			ea	1	5	21.2	71	
P	O		5920-240-4126	*	*	*				ea	1	5	21.2	71	
P	H		3020-369-9455	*	*	*	*			ea	1		32	84377	
P	H		5815-511-4438	*	*					ea	1		21.2	95275	
P	H		5815-537-7566	*	*					ea	1		21.2	77026	

SOURCE CD (1)	MAINT. CD (2)	REC. CODE (3)	BASIC ISSUE ITEMS LIST						(4) UNIT OF ISSUE	(5) QTY INC IN UNIT PACK	(6) QTY INC IN UNIT	(7) QTY AUTH	(8) ILLUSTRATIONS		
			(2) FEDERAL STOCK NUMBER	(3) DESCRIPTION									(a) FIGURE NUMBER	(b) ITEM OR SYMBOL NUMBER	
				MODEL											
			1	2	3	4	5	6							
P	H		6625-609-6874	*	*	*			TS-2/TG, TS-2A, B, C/TG (continued)	ea	1		32	77034	
P	H		5815-448-1902		*	*			GEAR, WORM: (60 wpm) 80063; SC-B-91479 (installed in equip)	ea	1		21.2	91283	
P	H		5815-412-6182		*	*			GEAR, WORM: (75 wpm) 80063; SC-B-319812 (mounted in equip)	ea	1		21.2	77025	
P	O		6240-196-6470	*	*	*	*		GEAR, WORM: (100 wpm) 80063; SC-B-319811 (mounted in equip)	ea	1	1	21.1	F1	
									LAMP, INCANDESCENT: 08806; 15T7N						
									NO ACCESSORIES, TOOLS, OR TEST EQUIPMENT ARE TO BE ISSUED WITH THIS EQUIPMENT						
									NO BASIC ISSUE ITEMS ARE MOUNTED IN OR ON THIS EQUIPMENT						

APPENDIX C

MAINTENANCE ALLOCATION

Section I. INTRODUCTION

C-1. General

This appendix provides a summary of the maintenance operations covered in the equipment literature for Test Sets, Teletypewriter TS-2/TG, TS-2A/TG, TS-2B/TG, and TS-2C/TG. It authorizes categories of maintenance functions on repairable items and components and the tools and equipment required to perform each function. This appendix may be used as a aid in planning maintenance operations.

C-2. Explanation of Format for Maintenance Allocation Chart

a. *Group Number.* Group numbers correspond to the reference designation prefix assigned in accordance with ASA Y32.16, Electrical and Electronics Reference Designations. They indicate the relation of listed items to the next higher assembly.

b. *Component Assembly Nomenclature.* This column lists the item names of component units, assemblies, subassemblies, and modules on which maintenance is authorized.

c. *Maintenance Function.* This column indicates the maintenance category at which performance of the specific maintenance function is authorized. Authorization to perform a function at any category also includes authorization to perform that function at higher categories. The codes used represent the various maintenance categories as follows:

Code	Explanation
C	Operator/Crew
O	Organizational Maintenance
F	Direct Support Maintenance
H	General Support Maintenance
D	Depot Maintenance

d. *Tools and Equipment.* The numbers appearing in this column refer to specific tools and equipment which are identified by these numbers in section III;

e. *Remarks.* Self explanatory.

C-3. Explanation of Format for Tool and Test Equipment Requirements

The columns in the tool and test equipment requirements chart are as follows:

a. *Tools and Equipment.* The numbers in this column coincide with the numbers used in the tools and equipment column of the MAC. The numbers indicate the applicable tool for the maintenance function.

b. *Maintenance Category.* The codes in this column indicate the maintenance category normally allocated the facility.

c. *Nomenclature.* This column lists tools, test, and maintenance equipment required to perform the maintenance functions.

d. *Federal Stock Number.* This column lists the Federal stock number.

e. *Tool Number.* Not used.

SECTION II. MAINTENANCE ALLOCATION CHART

GROUP NUMBER	COMPONENT ASSEMBLY NOMENCLATURE	MAINTENANCE FUNCTIONS										TOOLS AND EQUIPMENT	REMARKS	
		I N S P E C T	T E S T	S E R V I C E	A D J U S T	A L I G N	C A L I B R A T E	I N S T A L L	R E P L A C E	R E P A I R	O V E R H A U L			R E B U I L D
1	TEST SET, TELETYPEWRITER TS-2/TG, TS-2A, B, C/TG	C		C F F									3 3	Preventive Maintenance Lubrication
			C F H										1 1,2,3,4	Operational Continuity All tests Motor speed
					C F H								3 1,2,3 1,2,3,4	Brushes, spring tension All adjustments.
						D							3 3,4	Replace brushes All repairs
1a	MOTOR, AC							F					3 3,4 4	Replace brushes All repairs
									F H				3 3,4 4	Replace brushes All repairs

SECTION III. TOOL AND TEST EQUIPMENT REQUIREMENTS

TOOL AND TEST EQUIPMENT REQUIREMENTS				
TOOLS AND EQUIPMENT	MAINTENANCE CATEGORY	NOMENCLATURE	FEDERAL STOCK NUMBER	TOOL NUMBER
		TS-2/TG, TS-2A, B, C/TO (continued)		
1	F, H, D	MULTIMETER Tf-352D/U (WILL BE REPLACED BY N/JSM-223)	6625-581-2036	
2	H, D	TEST SET TELETYPEWRITER TS-383/TG (REPLACE BY AN/USM-1)	6625-222-1714	
3	F, H, D	TOOL EQUIPMENT TE-50B	5180-356-4602	
4	H, D	TOOL EQUIPMENT TF-111	5180-408-1877	

By Order of the Secretary of the Army:

HAROLD K. JOHNSON,
General, United States Army,
Chief of Staff.

Official:

KENNETH G. WICKHAM,
Major General, United States Army,
The Adjutant General.

Distribution:

Active Army:

USASA (2)	USATC Armor (2)
CNGB (1)	USATC (Engr) (2)
CC-E (7)	USATC (Inf) (2)
Dir of Trans (1)	WRAMC (1)
CofEngrs(1)	Army Pic Cen (2)
TSG (1)	USACDCEC (10)
CofSptS (1)	Sig FLDMS (2)
USAARENBD (2)	AMS (1)
USAAESWBD (5)	Instls (2) except
USACDCEA (1)	Ft Hancock (4)
USACDCCBRA (1)	Ft Gordon (10)
USACDCCEA (1)	Ft Huachuca (10)
USACDCCEA:	Ft Carson (25)
Ft Huachuca (1)	Ft Knox (12)
USACDCOA (1)	WSMR (5)
USACDCQMA (1)	Gen Dep (2)
USACDCTA (1)	Sig See Gen Dep (5)
USACDCADA (1)	Sig Dep (12)
USACDCARMA (1)	A Dep (2) except
USACDCARTYA (1)	LBAD (14)
USACDCSWA (1)	SAAD (30)
USAMC (5)	TOAD (14)
USCONARC (5)	LEAD (7)
ARADCOM (5)	SHAD (3)
ARADCOM Rgn (2)	NAAD (5)
OS Maj Comd (4)	SVAD (5)
USARJ (5)	CHAD (3)
USARHAW (5)	ATAD (10)
USA Panama (5)	USAERDAA (2)
USARYIS (5)	USAERIDAW (13)
LOGCOMD (2)	USACRREL (2)
USAMICOM (4)	USAEPG (5)
USASTRATCOM (4)	MAAG: Rep of China (5)
USASTRATCOM-SO (8)	Vietnam (5)
USAESC (70)	JUSMMAT (6)
MDW (1)	USACSA Taiwan (5)
Armies (2) except	Units org under fol TOE:
Eighth (6)	(2 copies each)
Corps (2) .	6-15 11-97 11-158
USAC (3)	6-616 11-98 11-225
Svc Colleges (2)	7 11-99 11-226
USASCS (6)	7-100 11-117 11-237
USASESCS (6)	11-6 11-127 11-247
USAADS (2)	11-56 11-137 11-327
USAAMS (2)	11-57 11-147 11-347
USAARMS (2)	11-85 11-156 11-57
USAIS (2)	11-86 11-156 11377
USAES (2)	11-95 11-157 11-500

(AA-AC,	17	29-21	29-56	29-87	37
GF, GH,	17-100	29-25	29-56	29-106	37-100
XA, NB,	29-1	29-35	29-75	29-109	39-51
NC)	29-11	29-86	29-79	31-105	57
11-687	29-15	29-47	29-84	32-78	57-100
11-592	29-16	29-41	29-86	33S-6	
11-597	29-17	29-61			

NG: None.

USAR: None.

For explanation of abbreviations used, see AR 320-50.

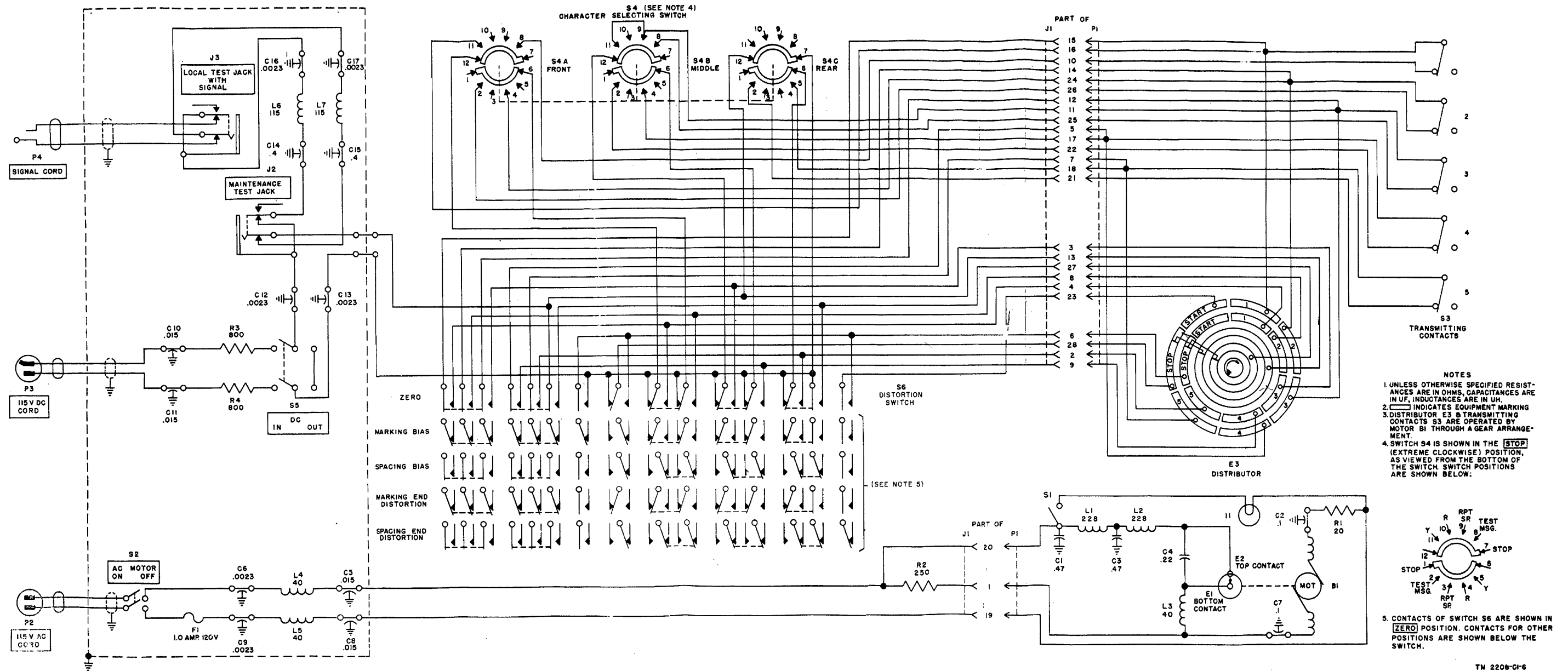

- NOTES
1. UNLESS OTHERWISE SPECIFIED RESISTANCES ARE IN OHMS, CAPACITANCES ARE IN UF, INDUCTANCES ARE IN UH.
 2. [Symbol] INDICATES EQUIPMENT MARKING.
 3. DISTRIBUTOR E3 & TRANSMITTING CONTACTS S3 ARE OPERATED BY MOTOR B1 THROUGH A GEAR ARRANGEMENT.
 4. SWITCH S4 IS SHOWN IN THE **STOP** (EXTREME CLOCKWISE) POSITION, AS VIEWED FROM THE BOTTOM OF THE SWITCH. BELOW POSITIONS ARE SHOWN BELOW:

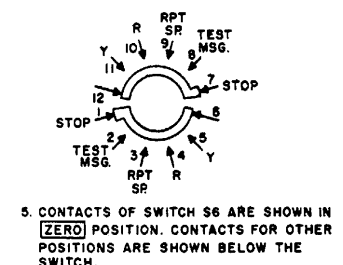
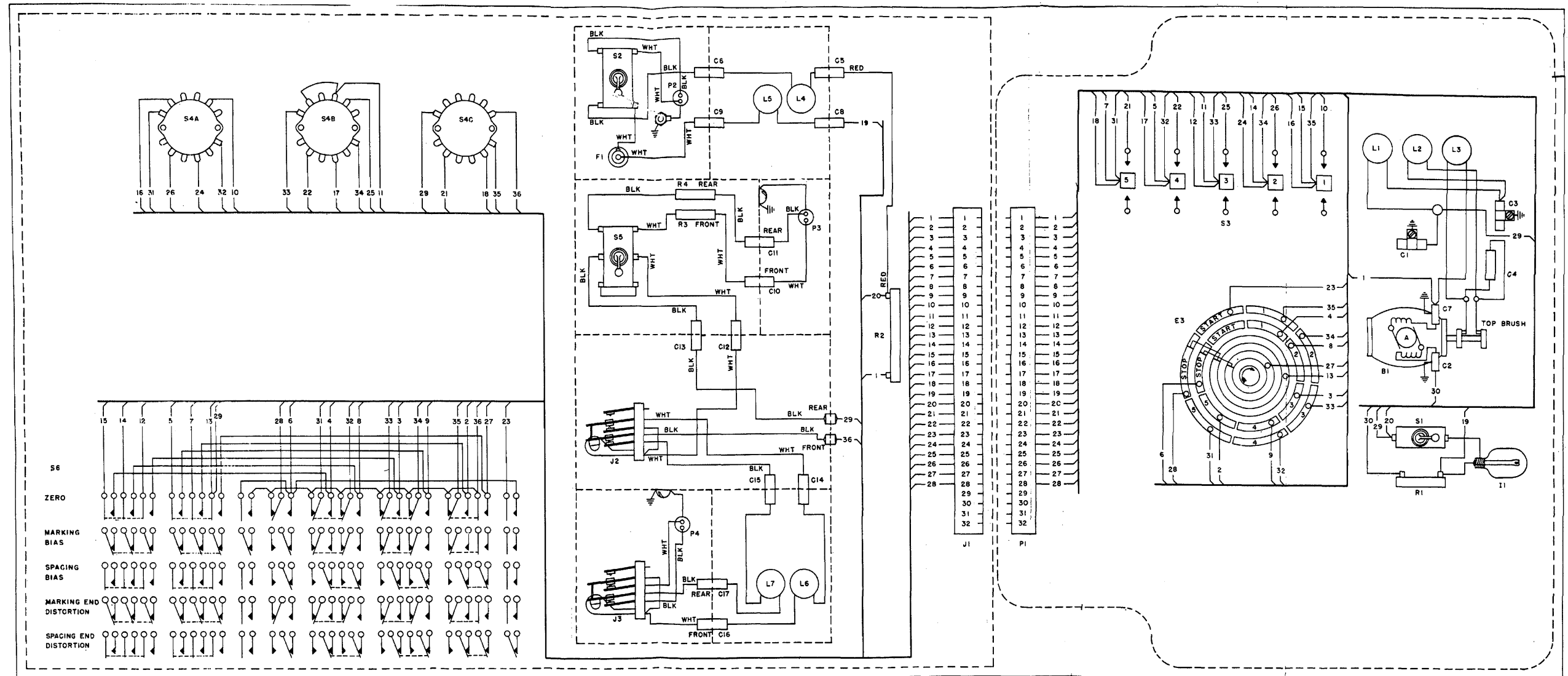

Figure 37. Test Set TS-2C/TG, schematic diagram.



TM 2208-CI-7

Figure 38. Test Set TS-2C/TG, wiring diagram.

CHANGE
NO. 6

HEADQUARTERS
DEPARTMENT OF THE ARMY
Washington, DC, 3 January 1984

**TEST SETS TS-2AB/TG (TELETYPEWRITER SIGNAL
DISTORTION) (NSN 6625-00-243-5173)**

TM 11-2208, 29 January 1957, is changed as follows:

Cover. The title is superseded as shown above.

Page 3, Paragraph 2. Delete paragraph 2 and substitute:

**2. Consolidated Index of Army Publications and
Blank Forms**

Refer to the latest issue of DA Pam 310-1 to determine whether there are new editions, changes or additional publications pertaining to the equipment.

Add paragraphs 2.1, 2.2, 2.3, 2.4 and 2.5 after paragraph 2.

2.1. Maintenance Forms, Records, and Reports

a. Reports of Maintenance and Unsatisfactory Equipment. Department of the Army forms and procedures used for equipment maintenance will be those prescribed by TM 38-750, The Army Maintenance Management System.

b. Report of Packaging and Handling Deficiencies. Fill out and forward SF 364 (Report of Discrepancy (ROD)) as prescribed in AR 735- 11-2/DLAR 4140.55/NAVMATINST 4355.73A/ AFR 400-54/MCO 4430.3F.

c. Discrepancy in Shipment Report (DISREP) (SF 361). Fill out and forward Discrepancy in Shipment Report (DISREP) (SF 361) as prescribed in AR 55-38/NAVSUPINST 4610.33C/ AFR 75-18/MCO P4610.19D/DLAR 4500.15.

**2.2. Reporting Errors and Recommending
Improvements**

You can help improve this manual. If you find any mistakes or if you know of a way to improve the procedures, please let us know. Mail your letter or DA Form 2028 (Recommended Changes to Publications and Blank Forms) direct to: Commander, US Army Communications-Electronics Command and Fort Monmouth, ATTN.: DRSEL-ME-MP, Fort Linn, New Jersey 07703. In either case, a reply will be furnished direct to you.

**2.3. Reporting Equipment Improvement
Recommendations (EIR)**

If your test set needs improvement let us know. Send us an EIR. You the user, are the only one who can tell us what you don't like about your equipment. Let us know why you don't like the design. Put it on an SF 368 (Quality Deficiency Report). Mail it to Commander, US Army Communications-Electronics Command and Fort Monmouth. ATTN.: DRSEL-ME-MP, Fort Monmouth, New Jersey 07703. We'll send you a reply.

2.4. Administrative Storage

Administrative Storage of equipment issued to and used by Army activities will have preventive maintenance performed in accordance with the PMCS charts before storing. When removing the equipment from administrative storage the

This change supersedes C5, 19 December 1973.

PMCS should be performed to assure operational readiness. Disassembly and repacking of equipment for shipment or limited storage are covered in chapter 7 and TM 740-90-1.

2.5. Destruction of Army Electronics Materiel

Destruction of Army electronics materiel to prevent enemy use shall be in accordance with TM 750-244-2.

Page 5. After paragraph 6 add:

6.1. Components Comprising the Operable End Item

NSN	Qty	Nomenclature, part No., and mfr code	Usable on code
6625-00-243-5173		Test Set, Signal Distortion TS-2AB/TG SCD91351	

Page 17. Delete section I and substitute:

Section I. OPERATOR/CREW PREVENTIVE MAINTENANCE CHECKS AND SERVICES

26. Scope

The maintenance duties assigned to the operator of Test Sets TS-2()/TG are listed below together with a reference to the paragraphs covering the specific maintenance function. The duties assigned do not require tools or test equipment.

- a. Operators preventive maintenance checks and services (para 29).
- b. Cleaning (para 30).

27. Preventive Maintenance

NOTE

Refer to TM 750-244-2 for proper procedures for destruction of this equipment to prevent enemy use.

a. Operator/crew preventive maintenance is the systematic care, servicing and inspection of equipment to prevent the occurrence of trouble, to reduce downtime, and to maintain equipment in serviceable condition. To be sure that your test set is always ready for your mission, you must do scheduled preventive maintenance, checks and services (PMCS).

(1) BEFORE OPERATION, perform your B PMCS to be sure that your equipment is ready to go.

(2) When an item of equipment is reinstalled after removal, for any reason, perform the necessary B PMCS to be sure the item meets the readiness reporting criteria.

(3) Use the ITEM NO. column in the PMCS table to get the number to be used in the TM ITEM NO. column on DA Form 2404 (Equipment Inspection and Maintenance Worksheet) when you fill out the form.

b. Routine checks like CLEANING, PRESERVATION, DUSTING, WASHING, Checking FOR FRAYED CABLES, STOWING ITEMS NOT IN USE, COVERING UNUSED RECEPTACLES, CHECKING FOR LOOSE NUTS AND BOLTS AND CHECKING FOR COMPLETENESS are not listed as PMCS checks. They are things that you should do any time you see they must be done. If you find a routine check like one of those listed in your PMCS, it is because other operators reported problems with this item.

NOTE

When you are doing any PMCS or routine checks, keep in mind the warnings and cautions.

WARNINGS

•Adequate ventilation should be provided while using TRICHLOROTRI-FLUOROETHANE. Prolonged breathing of vapor should be avoided. The solvent should not be used near heat or open flame; the products of decomposition are toxic and irritating. Since

TRICHLOROTRIFLUOROETHANE dissolves natural oils, prolonged contact with skin should be avoided. When necessary, use gloves which the solvent cannot penetrate. If the solvent is taken internally, consult a physician immediately.

- Compressed air is dangerous and can cause serious bodily harm if protective means or methods are not observed to prevent a chip or particle (of whatever size) from being blown into the eyes or unbroken skin of the operator or other personnel. Goggles must be worn at all times while cleaning with compressed air. Compressed air ship not be used for cleaning purposes except where reduced to less than 29 pounds per square inch gage (psig) and then only with effective chip guarding and personnel protective equipment. Do not use compressed air to dry parts when trichlorotrifluoroethane has been used.

NOTES

The PROCEDURES column in your PMCS charts instruct how to perform the required checks and services. Carefully follow these instructions and, if tools are needed or the chart so instructs, get organizational maintenance to do the necessary work. If your equipment must be in operation all the time, check those items that can be checked and serviced without disturbing operation. Make the complete checks and services when the equipment can be shut down.

c. Deficiencies that cannot be corrected must be reported to higher category maintenance personnel. Records and reports of preventive maintenance must be made in accordance with procedures given in TM 38-750.

28. Operator/Crew Preventive Maintenance Checks and Services

Perform before operation PMCS if you are operating the item for the first time.

NOTE

The checks in the interval column are to be performed in the order listed.

29. Operator/Crew Preventive Maintenance Checks and Services Chart

B - Before

Item No.	Interval B	Items to be Inspected	Procedures - Check for and have repaired or adjusted as Necessary	Equipment is not Ready/Available If:
1	•	Mission Essential Equipment	Check for completeness and satisfactory condition of the equipment. Report missing items.	Available equipment is insufficient to support the combat mission.
2	*	TS-2()/TG	Perform operational checks as described in paragraphs 17 through 21.	Test set fails to transmit properly.

*Do this check before each deployment to a mission location. This will permit any existing problems to be corrected before the mission starts. The check does not need to be done again until redeployment.

30. Cleaning

Inspect the exterior of the test sets including the radiation cover. The exterior surfaces should be clean, and free of dust, dirt, grease, and fungus.

- a. Remove dust and loose dirt with a clean soft cloth.

WARNING

Cleaning compound is flammable and its fumes are toxic. Provide adequate ventilation. Do not use near a flame.

- b. Remove grease, fungus, and ground-in dirt from the covers; use a cloth dampened (not wet)

with cleaning solvent (NSN 685000-105-3084).

c. remove dust or dirt from plugs and jacks with a brush.

d. Clean the control panels and control knobs; use a soft clean cloth. If dirt is difficult to remove, dampen the cloth with water; mild soap may be used for more effective cleaning.

Page 18. Delete section II and substitute'

31. Scope

This section contains information on the maintenance to be performed by the organizational maintenance technician. This maintenance consists of some removal and replacement, disassembly and reassembly, adjustments, isolation of faults, and repairing cordage and wiring.

32. Tools, Materials, and Test Equipment

a. Tool Equipment TE-50-B contains all tools necessary to maintain Test Sets TS-2(*)/TG.

b. Cleaning Compound (liquid form) which is necessary to maintain the test set is not contained in the TE-50-B.

c. multimeter AN/URM-105 is used to check the circuits of the test set.

33. Preventive Maintenance

Organizational preventive maintenance procedures are designed to help maintain equipment in serviceable condition. They include items to be checked and how to check them. These checks and services, described in paragraph 34, outline inspections that are to be made at specific monthly (M) intervals.

34. Organizational Preventive Maintenance Checks and Services Chart

M - Monthly

Item No.	Interval	Items to be Inspected	Procedures
	M		
1	•	TS-2()/TG	Perform operational checks as described in paragraphs 17 through 20.
2	•	Lubricate	Lubricate the test set as described in paragraphs 96 through 100.

Page 54. Change the title of chapter 7 to "SHIPMENT AND LIMITED STORAGE." Delete section II in its entirety. Appendix A. Delete appendix A and substitute:

APPENDIX A REFERENCES

DA Pam 310-1
TB 43-0118

TM 11-2217
TM 11-5500
TM 11-6625-364-12

TM 38-750
TM 43-0139
TM 740-90-1
TM 750-244-2

Consolidated Index of Army Publications and Blank Forms.
Field Instructions for Painting and Preserving Electronics Command Equipment Including Camouflage Pattern Painting of Electrical Equipment Shelters.
Distortion Test Sets TS-383/GG, TS383A/GG, and TS383B/GG.
Multimeter TS-297/U.
Organizational Maintenance Manual: Distortion Test Sets TS-383/GG, TS-383A/GG, and TS-383B/GG.
The Army Maintenance Management System (TAMMS).
Painting Instructions for Field Use.
Administrative Storage of Equipment.
Procedures for Destruction of Electronics Materiel to Prevent Enemy Use (Electronics Command).

Appendix B. Delete appendix B in its entirety.

By Order of the Secretary of the Army:

JOHN A WICKHAM JR.
General, United States Army
Chief of Staff

Official:

ROBERT M. JOYCE
Major General, United States Army
The Adjutant General

Distribution:

To be distributed in accordance with special list.

TEST SETS TS-2/TG, TS-2A/TG, AND TS-2B/TG

			Paragraph	Page
CHAPTER	1.	INTRODUCTION		
Section	I.	General-----	1,2	8
	II.	Description and data-----	3-6	8
CHAPTER	2.	INSTALLATION		
Section	I.	Service on receipt of equipment-----	7-9	6
	II.	Preinstallation-----	10-13	8
	III.	Signal connections-----	14-16	9
CHAPTER	3.	OPERATION		
Section	I.	Controls-----	17,18	14
	II.	Operation under normal conditions-----	19-21	14
	III.	Operation under unusual conditions-----	22-25	15
CHAPTER	4.	ORGANIZATIONAL MAINTENANCE		
Section	I.	First echelon (operator) maintenance-----	26-30	17
	II.	Second echelon maintenance-----	31-34	19
	III.	Adjustment procedures-----	35-57	21
CHAPTER	5.	THEORY		
Section	I.	Theory of test sets-----	58-60	29
	II.	Control mechanisms-----	61-638	51
CHAPTER	6.	FIELD MAINTENANCE INSTRUCTIONS		
Section	I.	General troubleshooting techniques-----	64-67	85
	II.	Removal and replacement-----	68-72	88
	III.	Repairs-----	73-95	89
	IV.	Lubrication-----	96-100	49
	V.	Weatherproofing-----	101,102	51
	VI.	Final testing-----	103-105	62
CHAPTER	7.	SHIPMENT AND LIMITED STORAGE AND DEMOLITION TO PREVENT ENEMY USE		
Section	I.	Shipment and limited storage-----	106, 107	54
	II.	Demolition of materiel to prevent enemy use-----	108, 109	54
INDEX		-----		57

* This manual supersedes TM 11-2208, 5 March 1948, including C 1, 7 February 1950, and C 2, 6 August 1952.

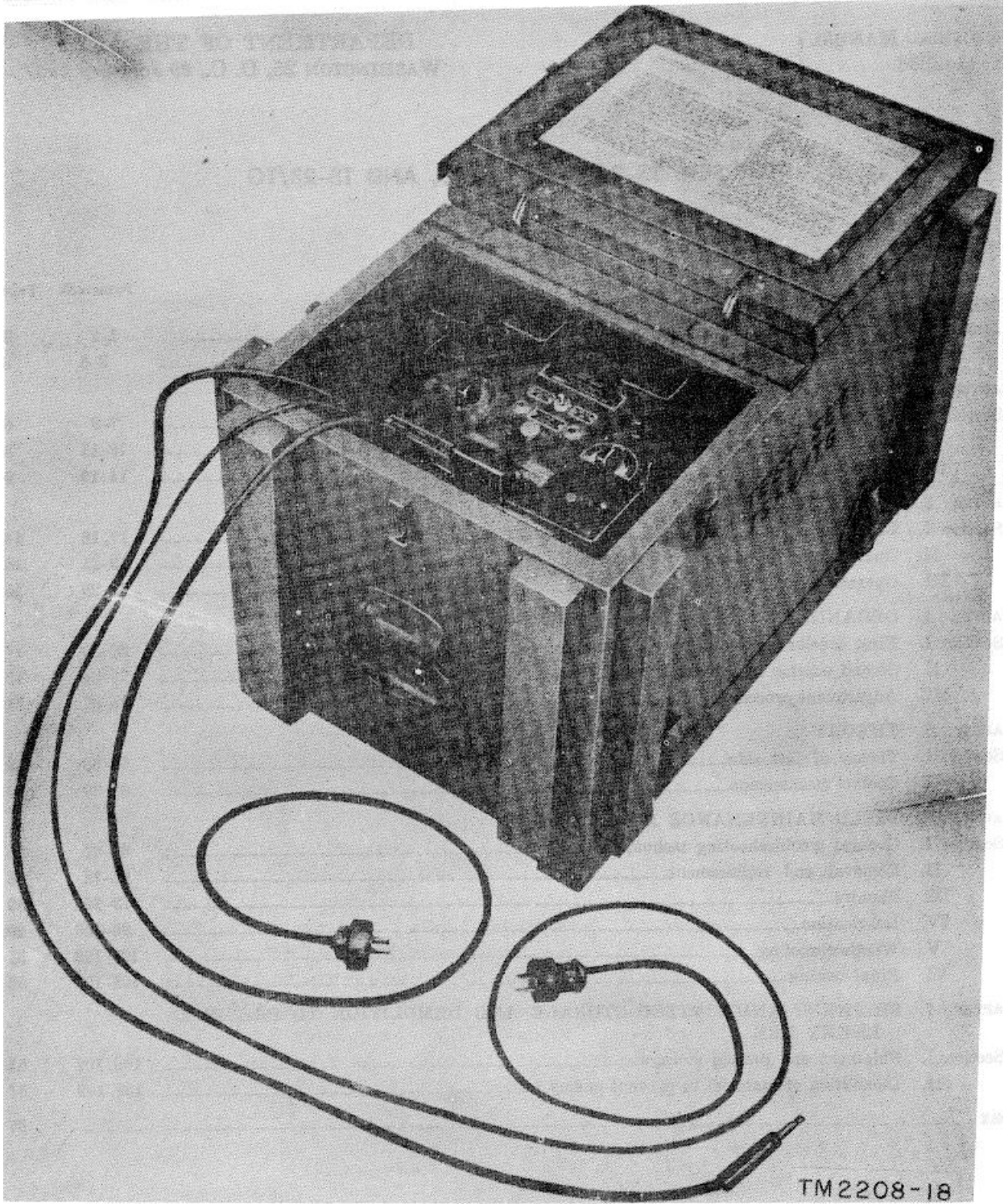

Figure 1. Test Set TS-2/TG.

CHAPTER 1 INTRODUCTION

Section I. GENERAL

1. Scope

- a. This manual covers the installation, operation, theory, maintenance, and repair of Test Sets TS-2(*) /TG (fig. 1).
- b. Basic nomenclature followed by (*) is used to indicate all models of the equipment covered herein. (Thus, Test Set TS-2(*)/TG refers to Test Sets TS-2/TG, TS-2A/TG, and TS-2B/TG.
- c. Forward comments on this publication directly to the Commanding Officer, The Signal Corps Publications Agency, Fort Monmouth, NJ

2. Forms and Records

- a. *Unsatisfactory Equipment Reports.* Fill out and forward DA Form 468 (Unsatisfactory Report) to Commanding Officer, Signal Equipment Support Agency, Fort Monmouth, NJ, as prescribed in AR 700-38.
- b. *Damaged or Improper Shipment.* Fill out and forward DD Form 6 (Report of Damaged or Improper Shipment) as prescribed in AR 700-58 (Army); Navy Shipping Guide, Article 1850- 4 (Navy); and AFR 71-4 (Air Force).
- c. *Preventive Maintenance Forms.*
 - (1) Prepare DA Form 11-252 (fig. 9) (Operator First Echelon Maintenance Check List for Signal Corps Equipment-Teletypewriter) in accordance with instructions on the back of the form.
 - (2) Prepare DA Form 11-253 (fig. 10) (Second and Third Echelon Maintenance Check List for Signal Corps Equipment-Teletypewriter) in accordance with instructions on the back of the form.

3. Purpose and Use

Test Sets TS-2(*)/TG are teletypewriter signal distortion test sets that are capable of sending normal or distorted signals for testing teletype writer circuits and equipment. They are used to determine operating margins of start-stop teletypewriter mechanisms and to test the efficiency of the selecting mechanisms in teletypewriter selector units. These test sets are also used to test and calibrate the bias meters of Line Units BE- 77-A, BE-77-B, and BE-77-C, and Switchboards BD-100 and BD-100-A. They may also be used with Allied (British) teletypewriter equipment operating at a speed of 404 operations per minute (opm).

4. Technical Characteristics

Type of installation-----	Tactical or fixed station; send only; direct wire.
Signaling code-----	Five-unit, start-stop; stop impulse length equals start impulse length multiplied by 1.42.
Types of signal-----	Neutral (60 milliamperes).
Speed -----	368.1, 404, 460, or 600 opm.
Power demand -----	Apr 100 watts.
Motor type -----	Series-governed.
Motor speed-----	2,100 revolutions per minute.
Motor power require-----	110 to 120 volts, 50- to 60-cycle, single phase alternating current.
Signal bias -----	0 to 50 percent, adjustable, marking or spacing bias.
End distortion-----	0 to 50 percent, adjustable, marking or spacing end distortion.
Suppression of interference with radio reception	Does not interfere with radio reception at frequencies between .15 and 1,000 megacycles when located 2 feet or more from radio antenna.
Weight -----	70 pounds.

5. Description

(figs. 1 and 2)

a. *General.* Test Set TS-2(*) TG is a self-contained unit, 23 inches long, 17 inches high, -(and 14 inches deep overall. It weighs 70 pounds. The test set is mounted on a base casting which is attached to a reinforced wooden base. A strongly reinforced wooden cover with two carrying handles houses the test set and fastens to the wooden base with four trunk-type latches. One half of the top of the wooden cover consists of a hinged lid. When this lid is open, it exposes the control panel, which is equipped with control switches and local test jacks, and permits the rest set to be operated without removing the wooden cover from the wooden base. Both the wooden cover and the wooden base are painted olive drab.

b. *Controls.* The control switches and jacks, with the exception of the target light and the radio filter cut-out switches, are mounted on the control panel which is located above the motor. A small door on the control panel permits access to the target light switch. The radio filter cut-out switch is mounted in the base casting of the test set.

c. *Motor.* The motor is an alternating current (ac) governed series motor which may be adjusted for use at 368.2 or 404 rpm.

d. *Cord.* The test set is equipped with all necessary signal and power cords.

e. *Spare Parts.* A small wooden box containing a spare target light, two spare fuses, sandpaper, two small brushes, is mounted on the wooden base at the motor end of the test set.

6. Differences in Models

In external appearance, the several models of the test sets vary slightly. The later models have been modified to improve operational features. The differences between the models of the test sets are given in the following table.

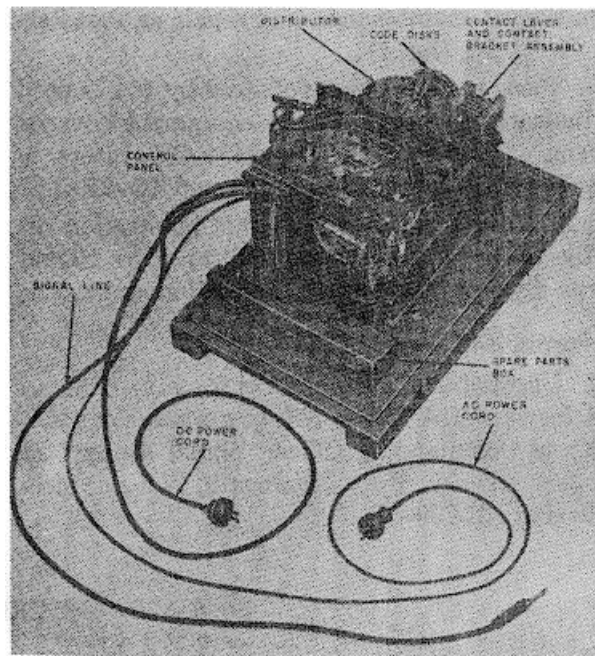

Figure 2. Test Set TS-2 TG, wooden cover removed

Item	TS-2/TG	TS-2A/TG	TS-2B/TG	TS-2B/TG Orders No. 25796-Phila-54, No. 31154-Phila-55, and No. 15598-Phila-55
Pointer and calibration scale.	Calibration scale is fixed, pointer is adjustable	Same as TS-2/TG	Same as TS-2/TG	Calibration scale is adjustable with respect to a fixed pointer. Lateral movement of the calibration scale is made possible by providing elongated calibration scale mounting holes.
Resistor (motor speed control).	2,500-ohm resistors .	Same as TS-2/TG	Same as TS-2/TG	The two 500-ohm resistors are replaced by a single 250-ohm resistor
Motor pinion guard	Mounted on the base casting	Same as TS-2/TG	Same as TS-2/TG	The motor pinion guard is mounted on the motor hub.
Resistor bracket assembly.	Mounted on the motor	Same as TS-21TG	Same as TS-2/TG	The resistor bracket assembly previously mounted on the motor is not used. A capacitor and resistor bracket assembly has been designed to accommodate this resistor.
Governor housing	Three-piece assembly; a governor shell, a front cover, and a target ring.	Same as TS-2/TG-	Same as TS-2/TG	The governor housing is made up of a rear cover, a governor shell, and a front cover. The target markings are placed directly on the front cover instead of on a separate target.
Capacitor and resistor bracket assembly.	Capacitor bracket assembly extends between the top surface of the base casting and the under surface of the control panel. It is turned so that the capacitor is facing inward, toward the motor.	Same as TS-2/TG	Same as TS-2/TG	The capacitor and resistor bracket assembly extend between the top surface of the base casting and the under surface of the control panel. It is turned so that these components are facing outward, making them easily accessible for-maintenance.
Control panel	Metal nameplates are used for panel markings.	Same as TS-2/TG	Same as TS-2/TG	Metal nameplates for the control panel are not used. The markings are not changed and are applied directly to the panel.
Motor bearings	Open face bearings. Require periodic lubrication.	Factory greased and sealed. Will require no further lubrication.	Same as TS-2A/TG	Same as TS-2A/TG.
Governor contact filter assembly.	Mounted inside the base casting	Mounted on the base casting.	Same as TS-2A/TG	Same as TS-2A/TG.
Base casting	Cast iron	Same as TS-2/TG	Aluminum.	Same as TS-2B/TG.

AGO 3686A

CHAPTER 2 INSTALLATION

Section I. SERVICE ON RECEIPT OF EQUIPMENT

7. Siting

Place the test set on a convenient workbench or table, or on the floor, near enough to the equipment to be tested so that connections can be made to the test set. Locate the test set so that the cords do not interfere with exposed wiring and cabling. When the equipment to be tested is located in a tent or temporary building, select a site for the test set that will be as free from moisture and dust as possible. In cases where a ground connection must be provided at the test site, locate the equipment as near as possible to a source of good ground.

8. Unpacking

(fig. 8)

a. Packaging Data. When packaged for export shipment, these test sets are packed with a dehydrating agent. The test set is blocked and braced by plywood sheets or pads of corrugated fiberboard. The fiberboard box is sealed in a moisture-vaporproof barrier, which, in turn, is in closed in a nailed wooden shipping case, reinforced with steel straps. Crated for shipment, the test set weighs approximately 160 pounds and has a volume of approximately 8.5 cubic feet.

b. Removing Contents. Be careful when unpacking equipment. Do not thrust tools into the interior of the shipping container; this procedure may damage the equipment. Follow the steps given below.

- (1) Place the packing case as near the operating position as possible and cut the steel straps.
- (2) Remove the nails, using a nail puller, and remove the sides and top of the packing case. Do not pry the sides and top off. This procedure may damage the equipment.
- (3) Remove the moisture proof barrier.
- (4) Slit the taped seams of the outer corrugated carton.
- (5) Remove the moisture-vaporproof barrier covering the inner corrugated carton.
- (6) Slit the taped seams of the inner corrugated carton, remove the corrugated filler and remove the test set.

9. Checking

- a.* Check the contents with the packing slip.
- b.* Examine the equipment carefully for possible damage during shipment.
- c.* Report damaged equipment in accordance with instructions contained in paragraph 2b.

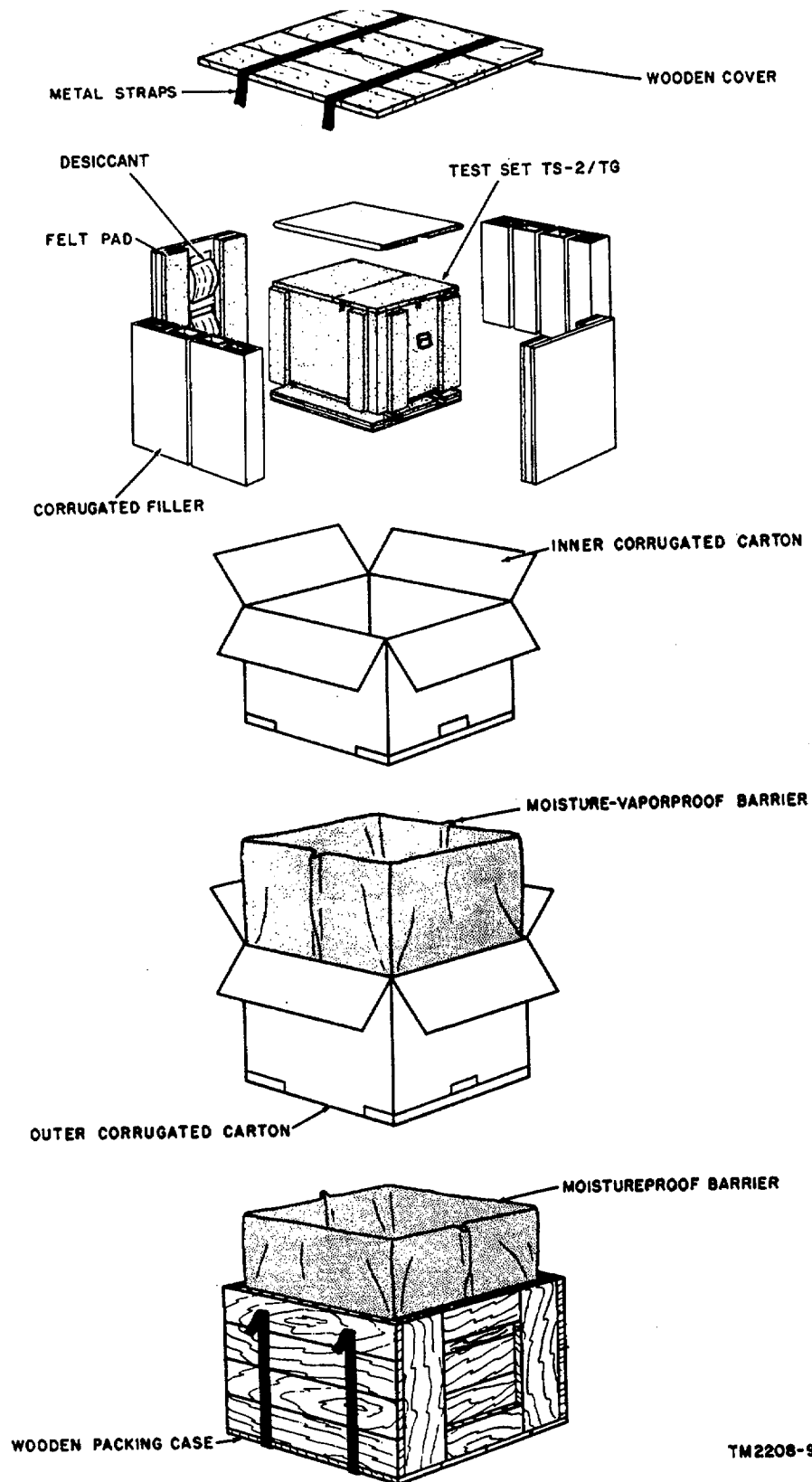

Figure 3. Test Set TS-2/TG, packaged for oversea shipment.

Section II. PREINSTALLATION SERVICES

10. Fuse Check

Check the motor fuse located in the base casting of the test set before applying power to the unit. This fuse is a plug type fuse rated at 16 amperes, 125 volts.

11. Preparation

a. *General.* These test sets are usually adjusted at the factory before being packed for shipment. Before any test set, new or used, is placed in service, make the checks outlined in *b* through *f* below.

b. *Lubrication.* Carefully check the lubrication requirements for the equipment. The code disks and gears should have a thin film of grease. If lubrication is required, follow the detailed lubricating instructions given in paragraph 100.

c. *Motor.* Turn the motor by hand in the normal direction of operation (counterclockwise when viewed from the governor end of the motor). Make certain that there is no binding between the motor pinion gear and the main shaft fiber gear, or that there is no binding in other parts of the equipment. If binding occurs, adjust according to instructions in paragraph 37.

Caution: Do not turn the motor in the wrong direction. This procedure will turn the distributor

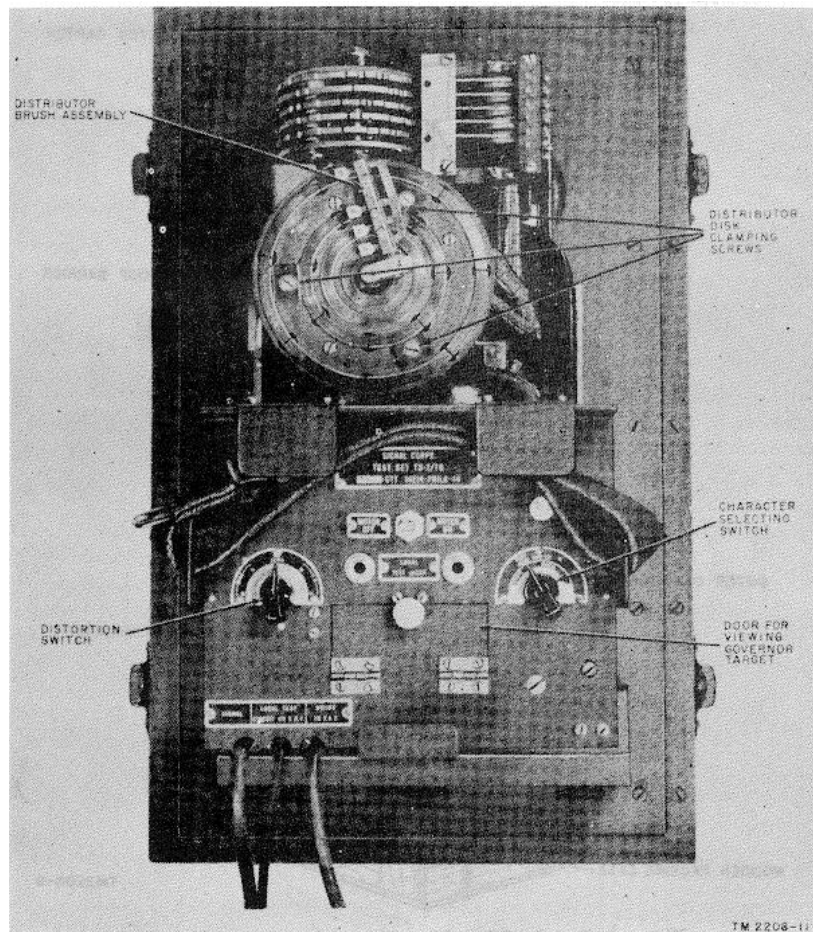

Figure 4. Test Set TS-2/TG, top view.

brushes backward and cause damage to the brush holders because the brushes may catch on the edges of the commutator segments.

d. Distributor Brushes. The distributor brushes should make contact with the commutator segments. They should have the proper tension and position (pars. 49 and 50).

e. Code Disk Transmitter. All contact tongues and contact springs should be undamaged.

f. Control Switches. Operate the switches to check freedom of action. Check the contacts for damage, dirt, and loose connections.

12. Motor Speed

a. Plug the ac power (MOTOR) cord into a source of 110- to 115-volt, 50- to 60-cycle ac.

b. Turn the motor switch to MOTOR ON and allow the motor to run a few minutes.

c. Open the door on the control panel (fig. 4) to expose the governor target, turn on the target lamp and adjust the motor speed as follows:

- (1) Strike an 87.6 vibrations-per-second (vps) (for 368.2 opm) or a 96.1 vps (for 404 opm) tuning fork against the palm of your hand to cause the tuning fork to vibrate. Do not strike the tuning fork against a metal or solid object or the fork may become damaged.
- (2) View the white target spots at the end of the motor governor through the vibrating shutters of the tuning fork. If the motor is operating at the correct speed, the target markings will appear stationary when viewed through the vibrating shutters of the tuning fork. If the motor is turning too fast, the target markings will appear to be moving in the direction of rotation. If the motor is turning too slow, the target markings will appear to be moving in the opposite direction.
- (3) If the motor speed is too fast, stop the motor and, if necessary, rotate the governor until the speed adjusting wheel is in its highest position above the armature shaft. Then turn the speed adjusting wheel counterclockwise about one-fourth turn. Start the motor and recheck the speed. Repeat the adjustment if necessary.
- (4) If the motor speed is too slow, follow the procedure given in (3) above, except that the speed adjusting wheel should be turned clockwise about one-fourth turn. Start the motor and recheck the speed. Repeat the adjustment if necessary.

13. Distortion Settings (Percentages)

For most tests, the adjustable distributor disk is set for 35 percent bias or end distortion; however, it may be set for any percentage, from 0 to 50. To set the percentage of distortion, first make the local test, preliminary checks and adjustments as instructed in paragraph 15a. Then loosen the adjustable distributor disk clamping screws (fig. 4) and rotate the disk counterclockwise until the printer is set for the desired (35) percent of bias or end distortion on the calibration scale. Tighten the three clamping screws.

Section III. SIGNAL CONNECTION

14. General

The test sets may be installed to meet several operational requirements. This variety is achieved by varying the connections of the signal lines to the test sets.

15. Power Connections

(fig. 4)

a. Local Test, Preliminary Checks and Adjustments.

(1) Set the motor switch to the MOTOR OFF position.

(2) Plug the ac power (MOTOR) cord into a source of 110- to 115-volt, 50- to 60- cycle ac.

(3) Plug the direct current (dc) power (LOCAL TEST) cord into a source of 115-volt dc.

(4) Plug the signal line (SIGNAL) cord into one of the LOCAL TEST JACKS.

(5) Plug a millimeter capable of measuring .060 ampere of current (accurately) into the other LOCAL TEST JACK.

(6) Turn the character selecting switch to the Y position.

(7) Loosen the adjustable distributor disk

clamping screws and rotate the disk clockwise until the pointer is off the calibration scale (fig. 22)

- (8) Move the distortion switch to the ED M position and turn the motor by hand slowly in the normal direction of rotation (counterclockwise when viewed from the governor end of the motor) until the brush arm approaches the beginning of the No. 5 segment of the stationary disk. Continue to turn the motor slowly until the millimeter just registers current. Observe the caution notice given in paragraph 11c.
- (9) Allow the brush arm to remain in this position and turn the distortion switch to the BIAS S position. The millimeter should now register no current.
- (10) Rotate the adjustable distributor disk ring slowly counterclockwise until the millimeter again just registers current. Tighten the adjustable distributor disk clamping screw
- (11) Adjust the position of the pointer by loosening the mounting screws and moving the pointer to 0 on the calibration scale. Tighten the pointer mounting screws. On Test Sets TS-2B/TG bearing Orders No. 25796-Phila-54, No. 31154-Phila-55, and No. 15598-Phila 55, the pointer and calibration scale has been modified by making the calibration scale adjustable with respect to a fixed pointer. Lateral movement of the calibration scale is made possible by providing elongated calibration scale mounting holes. After the adjustable disk ring has been clamped in position, loosen the calibration scale mounting screws and move the calibration scale so that the pointer registers 0 on the calibration scale. Tighten the mounting screws.

*b. Teletypewriter Connections with Test Set
Supplying Signal Current.*

- (1) Set the motor switches of the test set and the teletypewriter to the MOTOR OFF position.
- (2) Plug the signal line cord into one of the LOCAL TEST JACKS (fig. 5).
- (3) Plug the dc Dower cord into a source of 115-volt dc.-
- (4) Plug the receiving cord of the teletypewriter into the other LOCAL, TEST JACK.
- (5) Plug the ac power cords of the test set and the teletypewriter into a 110- to 115-volt 50- to 60-cycle ac source.
- (6) Set the character selecting and the distortion switches to the positions desired.
- (7) Turn the motor switches to the MOTOR ON position and perform the required tests (par. 2a and b).

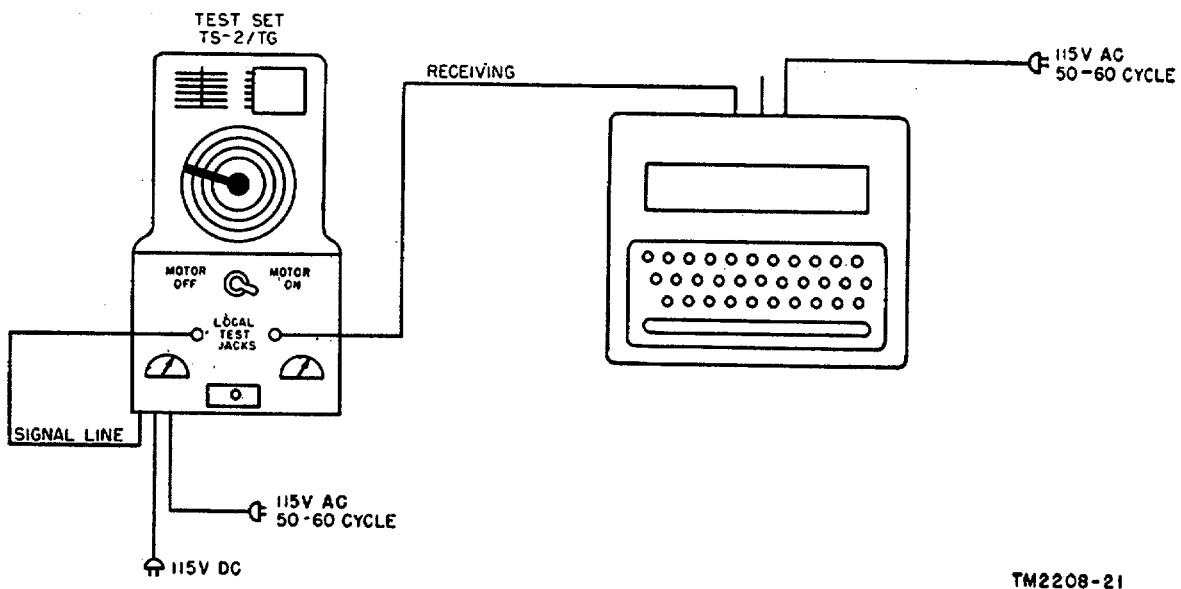

Figure 5. Connections for supplying signal current from the test set.

c. Teletypewriter Connections with Teletypewriter (Line Unit) Supplying Signal Current.

- (1) Set the motor switches of the test set and the teletypewriter to the MOTOR OFF position.
- (2) Set the character selecting switch to the STOP position.
- (3) Set the LOCAL DISTANT CURRENT SUPPLY switch of the line unit to the LOCAL CURRENT SUPPLY position.
- (4) Set the RELAY IN-OUT OF CIRCUIT switch of the line unit to the RELAY OUT OF CIRCUIT position.
- (5) Place a strap (short) between the LINE and GND binding posts of the line unit.
- (6) Plug the signal line cord of the test set into the BLK jack of the line unit (fig. 6).
- (7) Plug the red (receive) shell plug of the teletypewriter into the RED jack of the line unit. (The black shell (send) plug of the teletypewriter is not used for this installation.)
- (8) Plug the ac power cord of the test set into a suitable source of ac. (The dc power cord is not used for this installation.)
- (9) Plug the dc power cord of the line unit into a source of 115-volt dc.
- (10) Plug the ac power cord of the teletypewriter into a suitable source of ac.
- (11) Turn the rectifier (or other source of dc) on to supply dc. If a vacuum tube rectifier is used, allow sufficient time for the unit to warm up. Adjust the LINE RHEOSTAT of the line unit to obtain a 60 milliampere reading on the meter.
- (12) Set the character selecting and the distortion switches to the positions desired.
- (13) Turn the motor switches of the test set and teletypewriter to the MOTOR ON position and perform the required tests (par. 20a and b).

d. Bias Meter Test Connections for Line Units

BE-77-A, BE-77-B, and BE-77-C. It is not necessary to remove the bias meter from the line unit for testing and calibration.

- (1) Remove any plugs or teletypewriter connections from the line unit.
- (2) Place a strap (short) between the LINE and GND binding posts of the line unit.
- (3) Remove the line unit relay.
- (4) Remove the plug from the signal line cord of the test set.

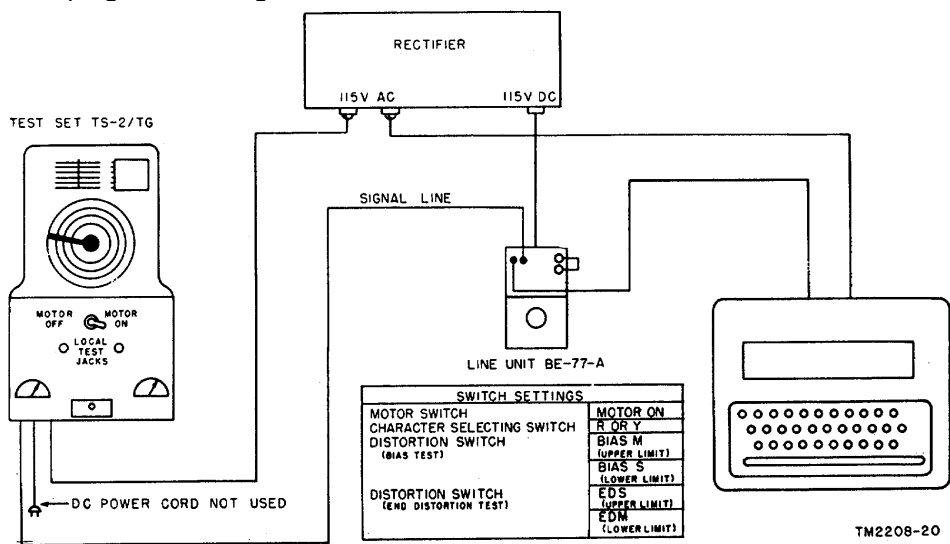

Figure 6. Connections for supplying signal current from the teletypewriter (line unit).

- (5) Using suitable alligator clips, attach one wire of the signal line cord to the center terminal of the relay mounting block and attach the remaining wire from the signal line cord to the top center terminal of the relay mounting block (fig. 7). If extensive tests of this nature are to be made, use a salvaged 41-C relay to make an adapter for these connections. Completely remove all parts of the relay such as coils, magnets, springs, contact points, and adjusting knob. Utilize the hole in the top of the plastic cover (after removing the white adjusting knob) to mount a jack. Wire the jack to the proper terminals of the salvaged relay so as to make connections with the specified terminals (center and top center) of the relay base within the line unit. This will eliminate the necessity of removing the plug from the signal line cord for this test.
- (6) Plug the dc power cord of the line unit into a source of 115-volt de.
- (7) Turn the filter switch on the test set to the FILTER OUT position.
- (8) Set the distortion switch to ZERO and the character selecting switch to RPT SP.
- (9) Set the meter switch on the line unit to BIAS. into a suitable source of ac. (The dc
- (10) Plug the ac power cord of the test set power cord is not used for this test.)
- (11) Turn the motor switch to the MOTOR ON position and perform the required test (par. 20c).

e. *Bias Meter Test Connections for Switch-*

board BD-100 and BD-100-A. It is not necessary to remove the bias meter from the switchboard for testing and calibration, or to remove the switchboard from service.

- (1) Plug the signal line cord of the test set into the BIAS METER jack of the switchboard. The switchboard must be connected to its regular source of dc (fig. 8).
- (2) Plug the ac power cord of the test set into a suitable source of ac. (The dc power cord is not used for this test.)
- (3) Turn the filter switch on the test set to FILTER OUT position.
- (4) Set the distortion switch to ZERO and the character selecting switch to RPT SP.
- (5) Set the switchboard METER key to the BIAS position.
- (6) Turn the motor switch of the test set to the MOTOR ON position and perform the required test (par.20d).

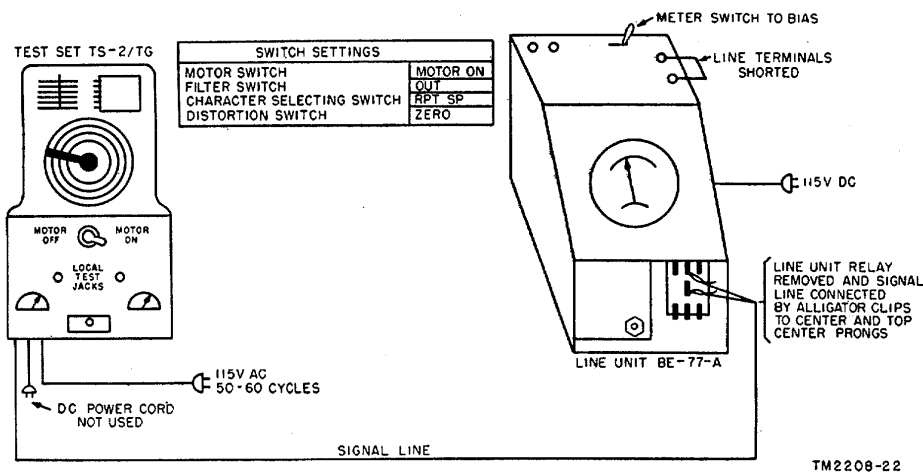

Figure 7. Connections for calibrating bias meter in line units.

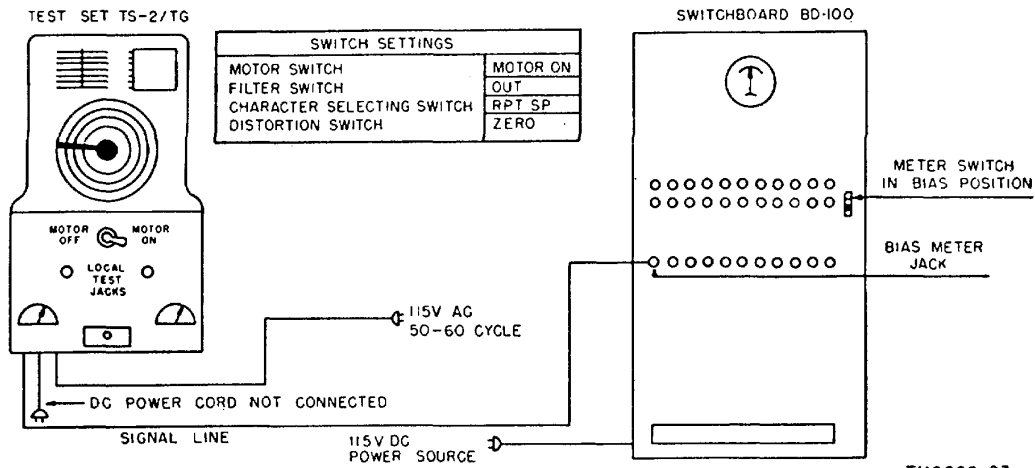

Figure 8. Connections for calibrating bias meter in switchboards.

16. Changing Operating Speed

Test Sets TS-2(*)/TG are shipped from the manufacturer ready for use on 60 words per minute (wpm) equipment. However, these test sets are capable of testing teletypewriter equipment utilizing either 75 or 100 wpm operation by replacing the existing drive gears with gears of a different ratio. These (motor pinion and main shaft) gears may be procured through regular supply channels when required;

CHAPTER 3

OPERATION

Section I. CONTROLS

17. General

The following chart lists all controls used in the operation of the test set. Operating personnel should become thoroughly familiar with the location and operation of each control before operating the equipment.

18. Controls

Control	Function
MOTOR ON MOTOR OFF switch.	Turns the motor on or off.
Distortion switch	Selects the type of distortion required. It may be set in any one of five positions: BIAS M (bias marking), BIAS S (bias spacing), ZERO (no distortion), ED M (end distortion marking), and ED S (end distortion spacing).
Character selecting switch.	Selects the type of repeated signals to be transmitted. It may be set in any one of five positions: STOP, TEST MSG (test message), RPT SP (repeat space), R, and Y.
FILTER OUT FILTER IN switch.	Disconnects the radio filter from the signal line.
Target light Toggle switch.	Turns the target lamp on or off.
Adjustable distributor disk.	Regulates the amount of distortion desired.
LOCAL TEST JACKS	Connects teletypewriter equipment to the test set.
Calibration scale and pointer or indicator.	Indicates the amount of distortion being transmitted.

19. Preliminary Starting Procedures

- a. Plug the ac power cord into a source of 110- to 115-volt, 50- to 60-cycle ac.
- b. Turn the motor switch to MOTOR ON and allow the motor to run for a few minutes.
- c. Turn on the target lamp and adjust the motor speed as directed in paragraph 12.
- d. Calibrate the distortion setting as directed in paragraph 15a.
- e. Loosen the adjustable distributor disk clamping screws and rotate the disk counterclockwise until the pointer is set for 35 percent bias or end distortion on the calibration scale. Tighten the adjustable distributor disk clamping screws. For most tests, the disk is set for 35 percent bias or end distortion; however, it may be set for any percentage from 0 to 50.

20. Types of Operation

The type of operation of the test set is determined by the distortion switch position. The positioning of the character selecting switch determines what letter or series of letters (R, Y, RPTP or TEST MSG) will be sent out on the signal line. The percentage of distortion, if any, is determined by the position of the adjustable distributor disk and is indicated on the calibration scale. The detailed switch settings for each condition are given in a through d below.

a. Bias Test of Teletypewriter Selector Unit.

- (1) Make the connections as directed in paragraph 15b when the test set is to supply current, or as directed in paragraph 15c if the teletypewriter is to supply current.
- (2) If the test set or the teletypewriter is equipped with governed motors, adjust the motor speeds as directed in paragraph 12.
- (3) Set the character selecting switch of the test set to either R or Y.

- (4) Set the distortion switch to BIAS M, which controls the transmission of signals with marking bias.
- (5) Check the range of the teletype machine to determine the upper limit of the range.
- (6) Set the distortion switch to BIAS S, which controls the transmission of signals with spacing bias.
- (7) Check the range of the teletype machine to determine the lower limit of the range.
- (8) Midway between these two settings is the point where the teletypewriter will tolerate the maximum bias. Determine the maximum amount of bias by use of the following formula:

$$\text{Maximum bias} = 35 + \frac{\text{Upper limit BIAS M} - \text{Lower limit BIAS S}}{2}$$

b. End Distortion Test.

- (1) Make the connections as directed in paragraph 15b when the test set is to supply current, or as directed in paragraph 15b if the teletypewriter is to supply current.
- (2) If the test set or the teletypewriter is equipped with governed motors, adjust the motor speeds as directed in paragraph 12.
- (3) Set the character selecting switch of the test set to either R or Y.
- (4) Set the distortion switch to ED M, which controls the transmission of signals with marking end distortion.
- (5) Check the range of the machine to determine the lower limit of the range.
- (6) Set the distortion switch to ED S, which controls the transmission of signals with spacing end distortion.
- (7) Check the range of the machine to determine the upper limit of the range.
- (8) The maximum amount of end Distortion the teletypewriter will tolerate can be determined from the following formula:

$$\text{Maximum end distortion} = 35 + \frac{\text{Upper limit ED S} - \text{Lower limit ED M}}{2}$$

c. Calibration of Line Units BE-77-A, BE-77-B, and BE-77-C Bias Meter. It is not necessary to remove the bias meter from the line unit for testing and calibration.

- (1) Install the test set and line unit as directed in paragraph 15d.
- (2) With the test set transmitting undistorted signals, the bias meter should indicate 0.
- (3) If it does not, adjust the small rheostat in the front of the line unit by first removing the nut which forms a cap covering and turning the adjusting screw with a screwdriver until the meter shows zero bias.
- (4) Tighten the cap on the rheostat securely to prevent accidental turning of the adjusting screw.

d. Calibration of Switchboard BD-100, BD-100-A Bias Meter. It is not necessary to remove the bias meter from the switchboard for testing and calibration, or to remove the switchboard from service.

- (1) Install the test set as directed in paragraph 15e.
- (2) With the test set transmitting undistorted signals, the bias meter should indicate 0.
- (3) If the meter does not indicate 0, adjust the rheostat, located at the bottom of the switchboard, until zero bias is obtained.

21. Stopping Procedure

- a. Turn the character selecting switch to the STOP position.
- b. Turn the distortion switch to the ZERO BIAS position.
- c. Turn the motor switch to the MOTOR OFF position.

22. General

a. Operation and maintenance of these test sets in arctic, tropical, or desert regions creates a number of problems peculiar to those regions. Moisture condensation due to extreme humidity causes short circuits and cross fire. Deterioration of parts due to rust and corrosion often results in a complete breakdown of the equipment. Dust,

dirt, or sand encountered in desert regions will affect operation and may cause equipment failure.

b. To prevent corrosion, keep the equipment as dry as possible. In cold regions, heat the shelter in which the test set is installed whenever possible. Use all possible measures to prevent quick changes in room temperature which might cause moisture condensation.

23. Operation in Arctic Climates

a. Provide a reliable source of heat whenever possible. A temperature of at least 40 F. Should be maintained in the room containing operating test equipment.

b. The Standard lubricants specified in paragraph 96 provide the proper lubrication for low temperature operation.

c. Allow the motor to run for a warm-up period of approximately 15 minutes.

24. Operation in Tropical Climates

Heat and humidity are the major climatic problems which must be overcome to permit reliable operation of this equipment in tropical areas.

a. High humidity may cause condensation of moisture on the equipment whenever the temperature of the equipment is lower than that of the surrounding area. Equipment corrosion and the presence of fungi -are inevitable results of this condition unless preventive measures are taken. A continuously light bulb placed within the equipment at the operating site can minimize corrosion and growth

b. The disadvantages of excessive heat may be partially or wholly overcome by providing, as much ventilation as possible around the test set, particularly around the motor. Increase friction caused by lack of lubrication and(l dirty. mechanisms also results in unnecessary heat.

25. Operation in Desert Climates

Operational problems in desert areas are much the same as those in tropical areas, except for the lack of humidity. Dryness may require more frequent lubrication. Dirt and dust can damage bearings and moving parts of mechanisms. Apply measures similar to those given for operation under tropical conditions to insure efficient operation of the equipment.

a. Protect the equipment against dust, dirt, and sand. Rustproof the shelter in which the equipment is installed. If necessary cover the inside walls with heavy paper.

b. Provide adequate ventilation to prevent overheating.

c. See that proper lubricants are used to protect the equipment.

d. Make frequent preventive maintenance checks.

CHAPTER 4

ORGANIZATIONAL MAINTENANCE

Section I. FIRST ECHELON (OPERATOR) MAINTENANCE

26. Scope

This section contains information on maintenance to be performed by the operator. This is accomplished by routine inspections, cleaning and visual checking of the test set.

27. Materials

The materials necessary to maintain the equipment at this level are as follows:

- a. Cheesecloth or other lint free cloth.
- b. Cleaning Compound, liquid form (Federal stock No. 7930395-9542).

28. Preventive Maintenance

a. *Inspections.* The test sets require regular inspections to detect and correct deficiencies caused by continuous use, as follows:

- (1) *Daily:* Check presence of running spares. Check all screws, bolts, and nuts on the chest. Check all electrical connections for firmness of seating and proper contact.
- (2) *Weekly:* Inspect the chest for cracks, missing or broken screws, damaged or worn load mountings; all wiring and cabling for cracks, rotting insulation, frayed, cut or gouged jacketing. Check operation of the test set for smoothness of operation, signs of wear, or evidence of the motor overheating.

b. *Deficiencies.* All deficiencies should be noted on DA Form 11-252 and brought to the attention of the technician at the next higher echelon of maintenance for correction.

29. Visual Inspection

a. *Wooden Cover.*

- (1) Inspect the wooden cover thoroughly. Look for cracks, marred painted surfaces, loose or missing screws, and faulty hinges. See that the latches are in good condition.
- (2) Clean the outer surfaces of the cover with a piece of cheesecloth slightly moistened with water. To remove oil, grease, or gummy stains on the outer surface of the wooden cover, slightly moisten the cloth with cleaning compound.

Warning: Prolonged breathing of cleaning compound fumes is dangerous. Make certain that adequate ventilation is provided. Cleaning compound is flammable; do not use near a flame.

b. *Test Set.*

- (1) Inspect the test set control panel for marred painted surfaces, missing or loose screws, dust and dirt.
- (2) Clean the outer or painted surfaces of the test set by using cheesecloth moistened with water or cleaning compound.
- (3) Check each switch knob to be sure that it is fastened securely to the switch.
- (4) Check all visible wiring for cracked or deteriorated insulation, frayed or cut insulation at connecting or supporting points, kinks, and strain caused by improper placement. Make certain that the outer insulating cover on cords and cables is wiped clean. Do not use oil or cleaning compound on rubber insulation.

c. *Miscellaneous.* Perform all additional maintenance checks listed in DA Form 11-252.

30. Use of Operators Preventive Maintenance

Form

(fig. 9)

a. DA Form 11-252 (fig. 9) is a preventive maintenance checklist to be used by the operator as directed by his commander.

**OPERATOR FIRST ECHELON MAINTENANCE CHECK LIST FOR SIGNAL CORPS EQUIPMENT
TELETYPEWRITER**

INSTRUCTIONS: See other side

EQUIPMENT NOMENCLATURE

TEST SET TS-2/TG

EQUIPMENT SERIAL NO.

38

LEGEND FOR MARKING CONDITIONS: ✓ Satisfactory; X Adjustment, repair or replacement required; ⊗ Defect corrected.
NOTE: Strike out items not applicable.

DAILY

NO.	ITEM	CONDITION						
		S	M	T	W	T	F	S
1	INSPECT UNIT FOR PRESENCE OF TOOLS, ACCESSORIES, AND RUNNING SPARES. PAR. 5a	✓	✓	✓				
2	TIGHTEN ALL LOOSE SCREWS, BOLTS, AND NUTS ON CHESTS, TELETYPEWRITER COVER, COMPONENT PANELS.							
3	CLEAN INSIDE AND OUTSIDE OF CHESTS AND TELETYPEWRITER COVER OF DIRT, GRIME, GREASE, RUST, OIL, GUMMY DEPOSIT. PAR. 29a	✓	✓	✓				
4	INSPECT THE COVER OF THE TELETYPEWRITER FOR CRACKED OR BROKEN GLASS, LOOSE SCREWS, BROKEN OR DAMAGED Hinges, DAMAGED BODYHOLDER, SCRATCHES.							
5	INSPECT ALL ELECTRICAL CONNECTIONS FOR FIRMLNESS OF SEATING AND PROPER CONTACT, CORROSION, GREASE, OIL. PAR. 29b	✓	✓	✓				
6	TIGHTEN ALL LOOSE ELECTRICAL CONNECTIONS.							
7	TIGHTEN ALL LOOSE SCREWS, LOCK, MOUNTING BOLTS ON TERMINAL BLOCKS, AND CLIP CONNECTORS.							
8	CLEAN EXTERIOR OF KEYS, SWITCHES, AND TERMINAL BLOCKS OF DIRT, GREASE, GRIME, MOISTURE. PAR. 29b	✓	✓	✓				
9	INSPECT EACH KEY OR SWITCH FOR PROPER MECHANICAL ACTION; FREEDOM OF MOVEMENT, POSITIVE ACTION, SPRING TENSION. LOOK FOR BROKEN, MISSING OR ILLEGIBLE KEY TOPS. PAR. 29b	✓	✓	⊗				

WEEKLY

NO.	ITEM	CONDI- TION	NO.	ITEM	CONDI- TION
11	INSPECT ALL WIRING AND CABLING FOR CRACKS, ROTTING INSULATION, FRAYED, CUT, OR GOUGED JACKETING, KINKS, PROPER SUPPORT WHERE REQUIRED, LOOSE TERMINATIONS, BROKEN CONDUCTORS. PAR. 29b		13	OPERATE THE TELETYPEWRITER AND CHECK FOR SMOOTH OPERATION, CLEAR PRINTING, SIGNS OF WEAR, EVIDENCE OF MOTOR OVER-HEATING.	

14 IF DEFICIENCIES NOTED ARE NOT CORRECTED DURING INSPECTION, INDICATE ACTION TAKEN FOR CORRECTION.

DA FORM 11-252
1 MAY 51

REPLACES DA AGO FORM 419, 1 DEC 50, WHICH IS OBSOLETE.

TM2208-31

Figure 9. DA Form 11-252.

b. Items not applicable to these test sets are lined out on figure 9. References in the item block in the figure are to paragraphs in this manual which contain additional maintenance information pertinent to the particular item.

Section II. SECOND ECHELON MAINTENANCE

31. Scope

This section contains information on the maintenance to be performed by the organizational maintenance consists of some removal and replacement, disassembly and reassembly, adjustments, isolation of faults, and repairing cordage and wiring.

32. Tools, Materials, and Test Equipment

- a. Tool Equipment TE-50-B contains all tools necessary to maintain Test Sets TS-2 (*)/TG.
- b. Cleaning Compound (liquid form) which is necessary to maintain the test set is not contained in the TE-50-B.
- c. Multimeter TS-297/U (part of TE-50-B) is used to check the circuits of the test set.

33. Preventive Maintenance

Preventive maintenance is work performed on equipment (usually when the equipment is not in use) to keep it in good working order so that breakdowns and needless interruptions in service will be kept to a minimum. Preventive maintenance differs from troubleshooting and repair in that its object is to prevent certain troubles from occurring. The technician at this level of maintenance should, in addition to performing all tasks assigned to the operator, check, remove, replace, repair, and adjust those items on DA Form 11-253 not crossed out (with the exception of item 29), and for which he is authorized replaceable parts.

34. Use of Second Echelon Preventive Maintenance Form

(fig. 10)

- a. DA Form 11-253 is a preventive maintenance checklist to be used by second echelon repairman as directed by his Commander.
- b. Items not applicable to Test Set TS-2(*)/ TG are lined out on figure 10. References in the ITEM block in the figure are to paragraphs in this manual which contain additional maintenance information pertinent to the particular item. Item 29, lubrication, although not crossed out on this form, will not be performed at this echelon of maintenance.

SECOND AND THIRD ECHELON MAINTENANCE CHECK LIST FOR SIGNAL CORPS EQUIPMENT TELETYPEWRITER					
EQUIPMENT NOMENCLATURE TEST SET TS-2/TG			EQUIPMENT SERIAL NO. 382		
INSTRUCTIONS: See other side					
LEGEND FOR MARKING CONDITIONS: ✓ Satisfactory; X Adjustment, repair or replacement required; ⊕ Defect corrected. NOTE: Strike out items not applicable.					
NO.	ITEM	1 2 3 4 5 6 7 8 9 10 11 12 13 14	NO.	ITEM	15 16 17 18 19 20 21 22 23 24 25 26 27 28 29
1	INSPECT UNIT FOR PRESENCE OF TOOLS , ACCESSORIES, AND RUNNING SPARES. PAR 5 a	✓	15	INSPECT THE CONTACTS OF SWITCHES AND REMS FOR PITTING, CORROSION AND WEAR. PAR 95	✓
2	REMOVE ALL LOOSE SCREWS, BOLTS, AND NUTS ON CHESTS, TELETYPEWRITER COVER, COMPONENT PARTS.	✓	16	ADJUST SPRING TENSION OF CONTACT SPRINGS, REMS AND SWITCH CONTACTS WHERE NECESSARY. PAR 57	✓
3	CLEAN INSIDE AND OUTSIDE OF CHESTS AND TELETYPEWRITER COVER OF DIRT, GREASE, GRIME, OIL, CORROSION PRODUCTS.	✓	17	CLEAN CONTACTS OF SWITCHES AND REMS OF DIRT, GREASE, DUST, CORROSION. PAR 73	✓
4	INSPECT THE COVER OF THE TELETYPEWRITER FOR CRACKS OR BURNED PLACES, LOOSE SCREWS, BRUSHES OR DAMAGED BRUSHES, DAMAGE TO TERMINALS, CONNECTIONS.	✓	18	CHECK THE SPRING UNIT AND TYPE BAR CARTRIDGE FOR CORROSION OF CONTACT SURFACES, DIRT FROM CONTACTS, CORROSION OF CONTACT SURFACES, DISTORTION OF CONTACT SURFACES, OTHER DAMAGE.	✓
5	INSPECT ALL ELECTRICAL CONNECTIONS FOR FIRMNESS OF SEATING AND PROPER CONTACT, CORROSION, GREASE, OIL. PAR 29b	✓	19	INSPECT THE SPRING UNIT FROM DAMAGING TYPE BAR CARTRIDGE FRAME BRUSHING, WEAR AND TEAR, DISTORTION OF CONTACT SURFACES, CORROSION OF CONTACT SURFACES, OTHER DAMAGE.	✓
6	TIGHTEN ALL LOOSE ELECTRICAL CONNECTIONS. PAR 29b	✓	20	INSPECT THE SPRING UNIT, TYPE BAR CARTRIDGE, MECHANISM FOR LOOSE OR MISSING SCREWS, FREE MOVEMENT OF ALL MOVING PARTS, OIL, GRIME, DISTORTION, OR BURN SURFACES, SCREWS, SPRINGS, BRUSHES, CARTRIDGES.	✓
7	TIGHTEN ALL LOOSE SCREWS, LUGS, MOUNTING BOLTS ON TERMINAL BLOCKS, AND SLIP CONNECTORS. PAR 29b	✓	21	ADJUST AND TIGHTEN ON SPRING UNIT WHICH REQUIRE ADJUSTMENT.	✓
8	CLEAN EXTERIOR OF REMS SWITCHES, AND TERMINAL BLOCKS OF DIRT, GREASE, GRIME, MOISTURE. PAR 29b	✓	22	INSPECT EACH BELL CRANK, CODE BAR, TYPE BAR, TO DETERMINE THAT ALL PARTS MOVE FREELY AND ARE NOT BENT OR BROKEN, THERE ARE NO MISSING OR DAMAGED PARTS.	✓
9	INSPECT EACH REMS SWITCH FOR PROPER MECHANICAL ACTION; FREEDOM OF MOVEMENT, POSITIVE ACTION, SPRING TENSION; LOOK FOR CRACKS, MISSING OR DISTORTED METAL PARTS. PAR 29b	✓	23	INSPECT GEARS, SHAFTS, BEARINGS OF TYPE BAR CARTRIDGE FOR SIGNS OF EXCESSIVE WEAR, LOOSE PARTS, DAMAGE. PAR 29b	✓
10	INSPECT CHESTS FOR DIRT, CRACKS, MISSING OR BROKEN SCREWS, RUST, DAMAGE, WORN LAMP MOUNTINGS. PAR 29b	✓	24	ADJUST ANY UNITS ON TYPE BAR CARTRIDGE THAT REQUIRE ADJUSTMENT. PAR 35 THROUGH 57	✓
11	INSPECT ALL WIRING AND CABLING FOR CRACKS, ROTTING INSULATION, FRAYED, CUT, OR GOUGED JACKETING, KINKS, PROPER SUPPORT WHERE REQUIRED, LOOSE TERMINATIONS, BROKEN CONDUCTORS. PAR 29b	✓	25	INSPECT THE MOTOR FOR SIGNS OF OVERHEATING, WORN BRUSHES, PROPER BRUSH SPRING TENSION. PAR 80 AND 81	✓
12	INSPECT TERMINAL BLOCKS FOR CRACKS, BREAKS, DIRT, LOOSE CONNECTIONS, LOOSE SCREWS AND MOUNTINGS.	✓	26	CLEAN THE MOTOR AND GOVERNOR ASSEMBLY OF DIRT, GREASE, FOREIGN MATTER. PAR 77	✓
13	OPERATE THE TELETYPEWRITER AND CHECK FOR SMOOTH OPERATION, CLEAR PRINTING, SIGNS OF WEAR, EVIDENCE OF MOTOR OVERHEATING.	✓	27	CLEAN OIL, GREASE, DUST, DIRT FROM MECHANISM, RE-SPRING, RE-SEVERE, AND REPAIR THE TRANSMITTING MECHANISM. PAR 95	✓
14	SOLDER ANY LOOSE OR BROKEN SOLDER CONNECTIONS. PAR 29b	✓	28	INSPECT THE MOISTURE AND FUMING PROBLEMS.	✓
			29	INSPECT GENERAL CONDITION OF LUBRICATION AND LUBRICATE AS REQUIRED ACCORDING TO LATEST DEPARTMENT OF THE ARMY LUBRICATION ORDER. PAR 100	✓
30. IF DEFICIENCIES NOTED ARE NOT CORRECTED DURING INSPECTION, INDICATE ACTION TAKEN FOR CORRECTION.					

DA FORM 11-253 (Formerly DA AGO) REPLACES DA AGO FORM 4'S, 1 DEC 38, WHICH IS OBSOLETE.

TM2208-32

Figure 10. DA Form 11-253.

AGO 3686A

Section III. ADJUSTMENT PROCEDURES

35. General

This section presents the requirements and adjustment procedures for the test set. Perform adjustments described in paragraphs 36 through 57 in the order presented.

36. Main Shaft Position

(fig. 11)

a. *Requirement.* The center of the main shaft fiber gear should line up with the center of the motor pinion gear.

b. *Adjustment.* Loosen the upper and lower bearing bracket mounting screws. Position the main shaft to meet the requirement. Tighten the upper and lower bearing bracket mounting screws.

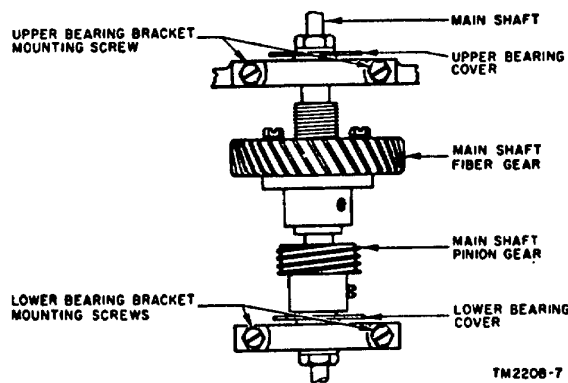

Figure 11. Main shaft assembly.

37. Motor Position

a. *Requirement.* There should be a minimum amount of backlash between the motor pinion gear and the main shaft fiber gear throughout a complete revolution of the main shaft.

b. *Adjustment.* Loosen the motor mounting screws and position the motor to meet the requirement. Tighten the motor mounting screws.

38. Governor Shell

(figs. 12 and 13)

a. *Preparation.* Remove the brush spring plate and governor cover (fig. 12). Remove the speed adjusting spring (fig. 13).

b. *Requirements.*

- (1) The governor contacts should meet squarely and there should be at least .010-inch clearance between the governor spring bracket and the rim of the governor shell.
- (2) There should be a gap of .015 to .040 inch between the governor contacts when they are open.

c. *Adjustments.*

- (1) Remove the governor shell from the armature shaft. Loosen the governor spring bracket mounting screws. Position the governor spring bracket to meet the requirement. Tighten the governor spring bracket mounting screws.
- (2) Bend the governor contact spring to meet the requirement. Replace the governor shell on the armature shaft. Replace the speed adjusting spring, the governor cover and the brush spring plate.

39. Governor Speed Adjusting Wheel Friction Washer

(figs. 12 and 13)

a. *Preparation.* Remove the brush spring plate and governor cover (fig. 12). Hook a 32-ounce

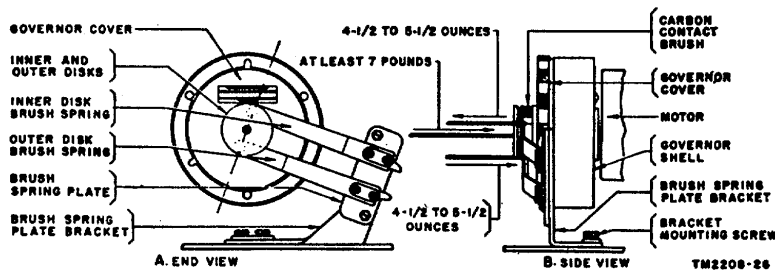

Figure 12. Governor assembly.

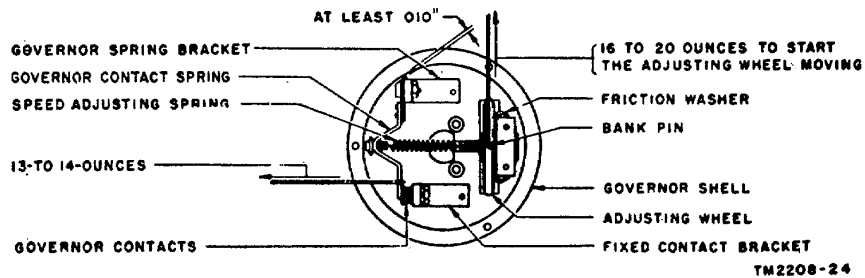

Figure 13. Governor shell, governor cover removed.

scale over the governor contact spring arm near the governor contacts and pull in line with the speed adjusting spring (fig. 13). Turn the speed adjusting wheel to the right or left until a pull of 13 to 14 ounces just separates the governor contacts.

b. *Requirement.* Hook a 32-ounce scale over a bank pin inserted radially in the leather of the speed adjusting wheel and pull at right angles to the radius of the wheel. A pull of 16 to 20 ounces should be required to start the wheel moving.

c. *Adjustment.* Remove the governor shell from the armature shaft. Remove the friction washer and bend the large projections to meet the requirement. Replace the friction washer, governor shell, governor cover, and the brush spring plate.

40. Governor Inner and Outer Disk Contact Springs

(fig. 14)

a. *Preparation.* Remove the brush spring plate and governor cover.

b. *Requirements.*

- (1) The distance from the inner surface of the governor cover to the highest point on the contact springs should be twenty-five thirty-seconds to twenty-seven thirty-seconds inch.
- (2) Place a D socket wrench over the nut located in the center of the governor cover. Using a 6-inch scale, measure the radial distance from the vertical surface of the wrench to the point where the scale touches the curved surface of the inner disk contact spring. This distance should measure seventeen thirty-seconds to nineteen thirty-seconds inch.
- (3) Measure the distance from the wrench to a point of contact on the outer disk contact spring in the same manner as described in (2) above. This distance should measure seven-sixteenths to one-half inch.

c. *Adjustments.* Bend the inner and outer disk contact springs to meet the requirements. Avoid sharp bends or the springs may break. Replace the governor cover and the brush spring plate.

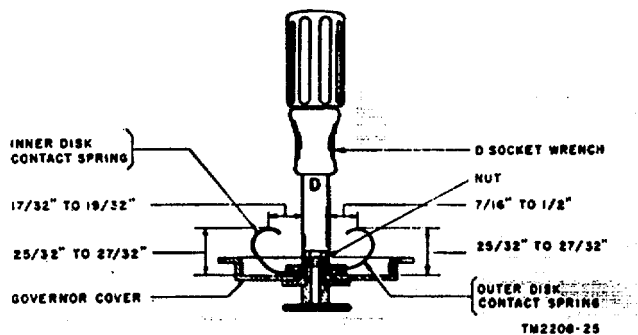

Figure 14. Governor inner and outer disk contact springs.

41. Governor Brush Spring Plate Bracket

(fig. 12)

a. *Requirements.*

- (1) A line through the center of the outer disk should pass through the center of each carbon contact brush.
- (2) The surface of the brush spring plate bracket on which the brush spring plate is mounted should be in line with the outer surface of that part of the governor cover on which the target is mounted.
- (3) The brush spring plate bracket should be parallel to the surface of the governor cover.

b. *Adjustment.* Loosen the brush spring plate bracket mounting screws. Position the brush spring plate bracket to meet the requirements.

AGO 3686A

Tighten the brush spring plate bracket mounting screws.

42. Governor Brush Spring Pressure

(fig. 12)

a. *Requirements.*

- (1) Apply an 8-ounce scale to the brush spring near each carbon brush and pull (inner disk brush spring) or push (outer disk brush spring) horizontally in line with the armature shaft. A pull or push of $4\frac{1}{2}$, to $5\frac{1}{2}$ ounces should be required to start each brush moving away from its associated disk.
- (2) Both carbon brushes should lie flat against their associated disks, and the outer edges of the brushes should be flush with or not more than three sixty-fourths inch inside the outer edges of the disks.

b. *Adjustments.* Loosen the two brush spring clamping screws and slip out the brush springs. Bend the springs to meet the requirements. Remount the springs and position them properly. Tighten the clamping screws.

43. Code Disk Shaft End Play

(fig. 15)

a. *Requirement.* The code disk shaft should have some end play, but not more than .006 inch.

b. *Adjustment.* Loosen the code disk assembly mounting screw. Position the code disk assembly on its shaft to meet the requirement. Tighten the code disk assembly mounting screw.

44. Intermediate Shaft End Play

(fig. 15)

a. *Preparation.* Remove the intermediate shaft gear guard.

b. *Requirement.* The intermediate shaft should have some end play, not more than .003 inch.

c. *Adjustment.* Unscrew the intermediate shaft collar setscrew and position the collar to meet the requirement.

Tighten the setscrew.

45. Intermediate Shaft Bakelite Gear

(fig. 15)

a. *Requirements.* The center of the intermediate shaft bakelite gear should be in line with the center of the main shaft pinion gear, and the play between the gears should be a minimum without binding throughout a complete revolution of the intermediate shaft bakelite gear.

b. *Adjustments.*

- (1) Loosen the intermediate shaft gear clamping screw and position the gear. Tighten the intermediate shaft gear clamping screw.
- (2) Loosen the four mounting screws that fasten the code disk assembly subbase to the distributor base and position the assembly to meet the requirement. Tighten the four mounting screws. Recheck adjustment in (1) above.

46. Code Disk Shaft Gear

(fig. 15)

a. *Requirements.* The code disk shaft gear should line up with the driving gear on the intermediate shaft, and the play between the gears should be a minimum without binding throughout a complete revolution of the code disk shaft gear.

b. *Adjustment.* Loosen the code disk bracket mounting screws. Position the code disk bracket to meet the requirement. Tighten the code disk bracket mounting screws.

47. Contact Bracket Assembly

(fig. 16)

Note. To check these adjustments, it will be necessary to remake them in accordance with the following instructions.

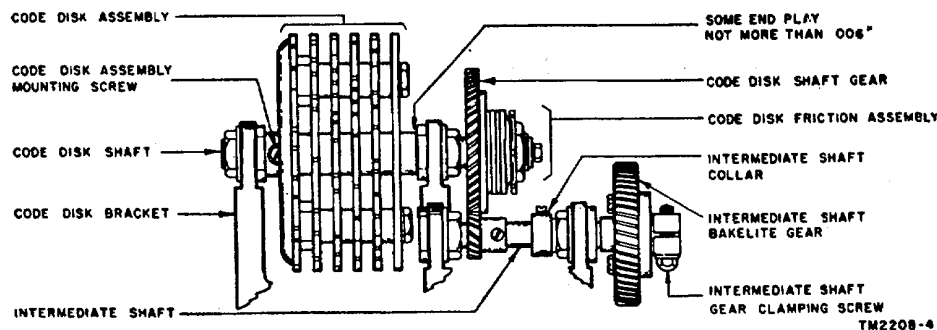

Figure 15. Code disk and intermediate shaft assemblies.

- a. **Contact Lever Bracket Position.**
 - (1) *Preparation.* Loosen the contact set screws and back off the upper and lower contact screws all the way. Rotate the motor manually until the No. 1 and No. 5 contact levers rest on a high part of their respective code disks.
 - (2) *Requirement.* There should be .002- to .030-inch clearance between the No. 1 and No. 5 upper contacts and their respective contact tongues.
 - (3) *Adjustment.* Loosen the bridge bracket mounting screws. Position the bridge bracket to meet the requirement. Tighten the bridge bracket mounting screws.
- b. **Contact Tongues.**
 - (1) *Preparation.* Rotate the motor manually until all the contact levers rest on the low part of their respective code disks.
 - (2) *Requirements.* Contact tongues Nos. 2, 3, and 4 should line up with contact tongues No. 1 and 5 with a variation not to exceed .030 inch.
 - (3) *Adjustment.* Bend the contact tongues as required.
- c. **Contact Screws.**
 - (1) *Preparation.* Rotate the motor manually until the No. 1 contact lever rests on the high part of its code disk.
 - (2) *Requirements and Adjustments.* Turn in the No. 1 upper contact screws so that it just makes contact with the No. 1 contact tongue. Then advance the screw $2\frac{1}{2}$ additional turns and tighten its set screw. Adjust the No. 1 lower contact screw until there is a gap of .006 to .010 inch between the tongue and the lower contact. Tighten the setscrew. Adjust Nos. 2, 3, 4, and 5 upper and lower contact screws in the same manner.

48. Contact Levers Spring Tension

(fig. 16)

- a. *Preparation.* Rotate the motor manually until the No. 1 contact lever rests on the low part of its code disk.
- b. *Requirement.* Hook an 8-ounce scale under the horizontal portion of the contact lever (the scalerod just clearing the contact tongue pivotal mounting) and pull up in a vertical line. A pull of 3 to 3 $\frac{3}{4}$ ounces should be required to separate the contacts.
- c. *Adjustment.* Loosen the spring anchor clamping screw. Position the spring anchor to meet the requirement. Tighten the spring anchor clamping screw. Adjust Nos. 2, 3, 4, and 5 contact lever springs in the same manner.

49. Distributor Brush

(fig. 17)

Note. If either of the brushes that ride on the two segmented rings is readjusted or replaced, the calibration adjustment described in paragraph 15a should be made.

- a. *Preparation.* Rotate the motor manually until

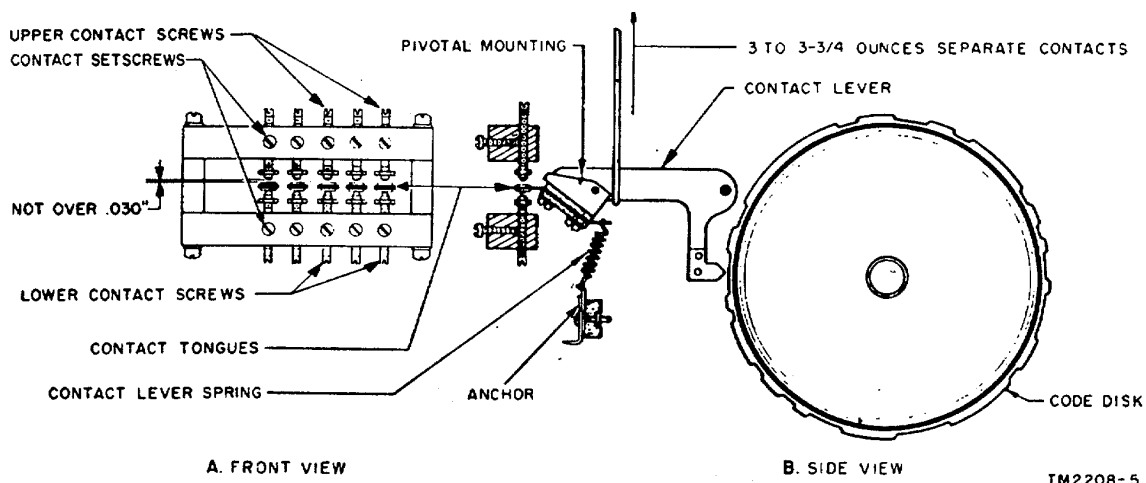

Figure 16. Contact lever and contact bracket assembly.

the brush arm is parallel to the inscribed line on the commutator disk.

b. *Requirement.* The trailing edge of the inner segment brush should make contact with its associated ring at a point in line (within .020 in.) with the inscribed line on the stationary disk. All brushes should be centrally located with respect to their associated commutator rings.

c. *Adjustment.* Loosen the brush spring clamping screws. Position the distributor brushes to meet the requirements. Tighten the brush spring clamping screws.

50. Distributor Brush Spring Tension

(fig. 17)

Caution: Replace brush springs that are kinked or have sharp bends.

a. *Requirement.* Hook an 8-ounce scale under the end of each distributor brush spring and pull upward at right angles to the end of the brush spring. A pull of 2 1/2 to 3 1/2 ounces should be required to lift the brush from its commutator ring.

b. *Adjustment.* Loosen the brush holder clamp screw until the brush holder is frictiontight. Rotate the brush holder clockwise until the brushes rest against the segments with a pressure of 2 1/2 to 3 1/2 ounces. Tighten the brush holder clamping screw.

c. *Resurfacing Brushes.* If it is necessary to readjust the brush holder to obtain the proper spring tension, the brushes should be resurfaced. Place a piece of No. 0000 sandpaper (approx 1-in. wide) face up on the distributor disk so that the brushes will pass over the sandpaper. Draw

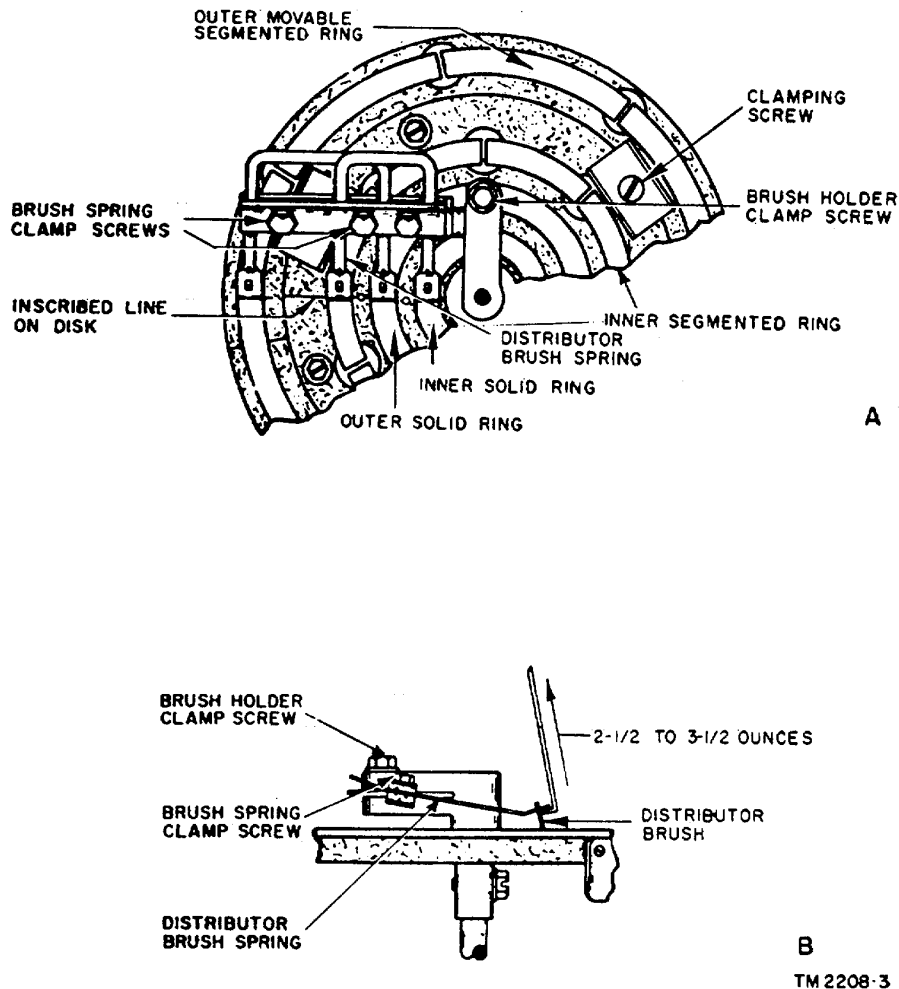

Figure 17. Distributor brush and brush spring.

the brushes across the sandpaper two or three times or until the bottoms of the brushes are parallel to the surface of the segments. Recheck the spring tension of each brush and readjust if requirements are not met.

51. Code Disk Position

a. *Requirement.* Each contact tongue should close with the lower (marking) contact before the distributor brush is within two segment lengths of the associated distributor segment and should remain closed until the brush has passed beyond the associated segment by two segment lengths. Use the inner segmented ring when checking these requirements. Refer to figures 15, 16, and 17 for location of parts.

b. *Adjustment.* Rotate the motor in its normal direction slowly by hand until the intermediate shaft bakelite gear clamping screw (fig. 15) is accessible. Continue to rotate the motor slowly until the No. 3 lower (marking) contact just closes. Loosen the clamping screw and, with the code disk (fig. 16) held stationary, again rotate the motor until the brush riding on the inner segmented ring (fig. 17) is within three segments, plus or minus one-half a segment length of the front end of the No. 3 segment. (One-half segment length refers to the length of one-half of any segment except the stop segment.) Tighten the clamping screw on the intermediate shaft bakelite gear. Recheck the requirement for all contacts. Check the code disk shaft end play (par. 43).

52. Code Disk Friction Assembly Torque

(fig. 18)

a. *Preparation.* Remove the intermediate shaft gear guard. Connect the motor power cord to 115-volt, 50- to 60-cycle ac and move the motor switch to MOTOR ON. Allow the motor to run for at least 10 minutes.

b. *Requirement.* With the motor running, hook a 32-ounce scale in the bottom of the slotted end of the friction drag lever (next to the stop post) and pull up vertically. A pull of 20 to 32 ounces should be required to start the arm moving away from the stop post.

c. *Adjustment.* Loosen the lock nut on the end of the code disk shaft and regulate the tension by the slotted nut. Tighten the lock nut. Move

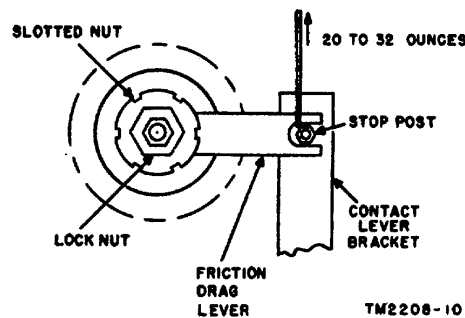

Figure 18. Code disk friction assembly.

the motor switch to MOTOR OFF. Replace the intermediate shaft gear guard.

53. Distortion Switch and Detent Cam

(fig. 19)

Note. Before making further adjustments, position the switch knob and detent cam to meet the following requirements.

a. Requirements.

- (1) The switch knob setscrew should engage the flat side on the shaft, and there should be some clearance, not to exceed .025 inch. between the knob and the dial.
- (2) The detent cam setscrew should engage the flat side on the small diameter end of the cam, and the vertical position of the cam should be such that the detent level roller rides centrally on the cam.

b. Adjustments.

- (1) Loosen the switch knob setscrew and position the switch knob to meet the requirements. Tighten the switch knob setscrew.
- (2) Loosen the detent setscrew and position the detent cam to meet the requirements. Tighten the detent cam setscrew.

54. Detent Lever

(fig. 19)

a. *Requirement.* With the detent roller in the center indent of the detent cam, the switch knob indicator should point to the center of the ZERO mark on the dial.

b. *Adjustments.* Loosen the detent lever eccentric mounting screw. Position the detent lever to meet the requirement. Tighten the detent lever eccentric mounting screw.

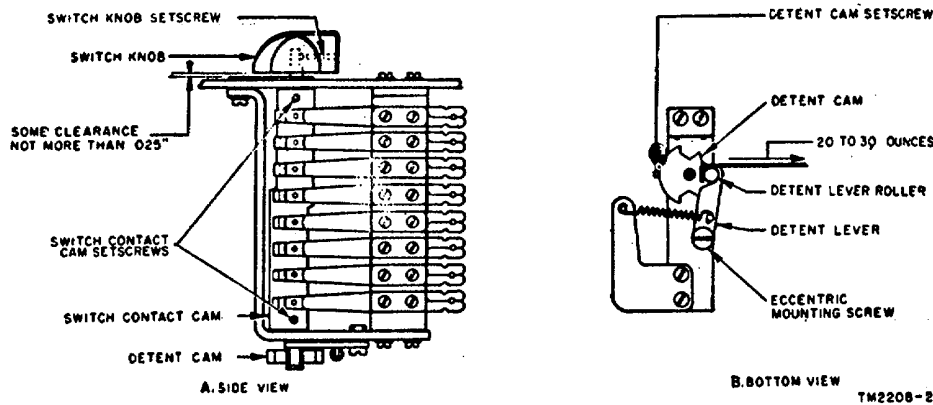

Figure 19. Distortion switch assembly.

55. Distortion Switch Contact Cam

(fig. 19)

- a. *Preparation.* Move the switch knob to the ZERO position.
- b. *Requirements.* The setscrews of the switch contact cam should be at right angles to the switch knob pointer and the heads of the setscrews should be toward the left side of the unit.
- c. *Adjustments.* Loosen the switch contact cam setscrews. Position the switch contact cam to meet the requirement. Tighten the switch contact cam setscrews.

56. Switch Detent Lever Spring Tension

(fig. 19)

- a. *Requirement.* With the detent lever roller in an indent on the detent cam, hook a 32-ounce scale over the detent lever roller and pull horizontally and at right angles to the detent lever. A pull of 22 to 30 ounces should be required to start the detent lever roller moving away from the detent cam.
- b. *Adjustment.* If the requirement is not met, replace with a new spring.

57. Distortion Switch Contact Assembly

(fig. 20)

- a. *Preparation.* Move the switch knob to the ZERO position.
- b. *Requirements and Adjustments.*
 - (1) The contact pile-ups (numbered 1 to 8, from top to bottom) should be as follows:
 - No. 1-All open.
 - No. 2-All open.
 - No. 3-Open.
 - No. 4-Back closed, front open.
 - No. 5-Back closed, front open.
 - No. 6-Back closed, front open.
 - No. 7-Back closed, front open.
 - No. 8-Open.
 - (2) With the switch knob at the ZERO position, the eight cam follower springs should bear against the cam. While holding the long contact springs (swingers) out of the way, hook an 8-ounce scale over the end of each cam follower spring at the cam and pull at right angles to the spring. A pull of not more than 1 ounce should be required to start each spring moving away from the cam. Adjust by bending the springs.
 - (3) Turn the switch knob to the EDM position. The cam follower spring of the pile-ups No. 3 to No. 8 inclusive should assume the same position (within .010 in.) as in the ZERO position. If necessary, refine the switch contact cam adjustment (par. 55). Turn the switch knob to the BIAS S position and check the cam follower springs of contacts No. 1 and No. 2 for the same requirements.
 - (4) With the switch knob in the ZERO position, the long contact springs (swingers) should bear against the cam follower spring or the next inner long contact spring (swinger). Hold the short contact springs and the outer long contact springs (swingers) out of the way while measuring the pressure of the inner long contact springs. Hold the short contact springs out of the way while measuring the pressure of the outer long contact springs

(swingers) of pile-ups No. 5 and No. 6. Hook an 8-ounce scale over the end of the long contact springs (swingers) and pull at right angles to the springs. A pull of 1 1/2 to 3 ounces should be required to start the springs moving. Adjust, by bending the springs.

- (5) Turn the switch knob to the EDS position. The contacts which were closed (when the switch knob was in the ZERO position) should now have a gap of .015 to .025 inch. Adjust by bending the short contact springs.
- (6) Turn the switch knob to the ZERO position. The contacts which are now open should have a contact gap of .015 to .025 inch. Adjust by bending the short contact springs. With the switch knob in the ZERO position the swinger spring studs of pile-ups No. 4 to No. 7 inclusive may not normally rest against the preceding swinger or cam follower springs. This is permissible if the requirements in (3) and (4) above are met.

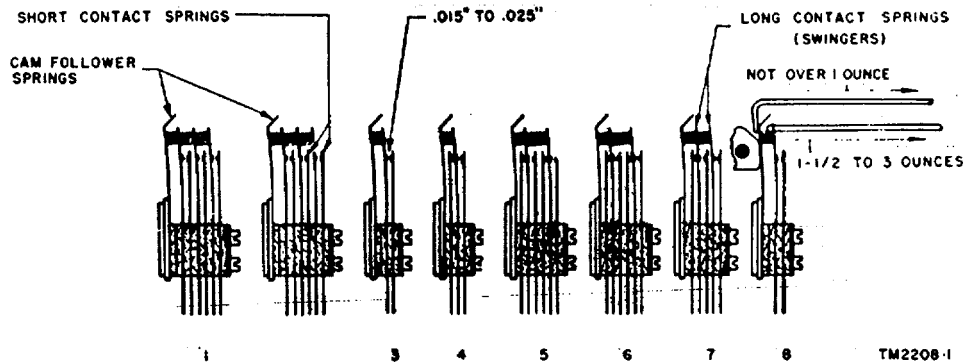

Figure 20. Distortion switch contact assembly.

CHAPTER 5

THEORY

Section I. THEORY OF TEST SETS

58. General

This chapter contains a complete explanation of the theory of operation of Test Sets TS-2 (*)/ TG. The first section covers the overall fundamentals of the test sets and the second section explains the overall theory of operation of the various control mechanisms.

59. The Distributor

a. The distributor face is equipped with four concentric rings. The two outer rings are segmented and the two inner rings are solid conductor rings. The outer segmented ring is movable so that it can be adjusted with respect to the inner segmented ring to send any amount of distortion from 0 to 50 percent. The amount of distortion is indicated on the scale at the side of the distributor disk. An overall view of the distributor is shown in figure 21.

b. Attached to the main shaft assembly is a brush holder assembly (fig. 21). The brush holder assembly mounts two sets of brushes which are drawn, in a clockwise direction, across the concentric distributor rings. One pair of brushes makes contact with the outer (movable) segmented ring and the outer solid ring. When undistorted signals are transmitted, these brushes are the only ones involved. The other pair of brushes makes contact with the inner segmented ring and the inner solid ring. Both sets of brushes and rings are used to transmit distorted signals by connecting the corresponding segments of the movable ring and the stationary ring electrically, either in series or in parallel.

c. The distributor rings are electrically connected, through the transmitting contacts and the character selecting switch, to the signal line. This provides a means of transmitting the signals at the correct speed and sequence to the equipment under test.

d. The segmented rings correspond to the impulses of the teletypewriter code; that is, a *start* segment for the start impulse, five *code* segments for the intelligence impulses, and a stop segment for the stop impulse. The distributor brushes make one complete revolution to transmit the code combination for each character or function. When a brush passes over the start segment, a *spacing* impulse is always transmitted. When a brush passes over the stop segment, a *marking* impulse is always transmitted. These two impulses keep the distributor and the receiving teletypewriter equipment in step or synchronism. A detailed explanation of the selection of character impulses is given in paragraph 61.

e. Distortion is introduced into the signal by positioning the outer movable segmented ring and by connecting these rings in either series or parallel by means of the distortion switch before completion of the electrical path to the signal line. Exact details of this procedure are discussed in paragraph 62.

60. Code Disk Transmitter Assembly

a. The code disk transmitter-assembly (fig. 22) consists principally of five code disks, five contact levers, five contact tongues, and ten contacts. The code disks are driven by an intermediate shaft assembly which, in turn, is driven by the main shaft through a gear arrangement.

b. The five contact levers pivot about a shaft in the contact lever bearing. At the outer end of the contact levers are pivotal mountings. Attached to these mountings, but insulated from them by fiber insulators, are contact tongues which ride between the upper (spacing) and lower (marking) contacts. Springs are connected between the contact tongues and a terminal block. These springs serve a dual purpose. They hold the contact tongues on the lower contacts until

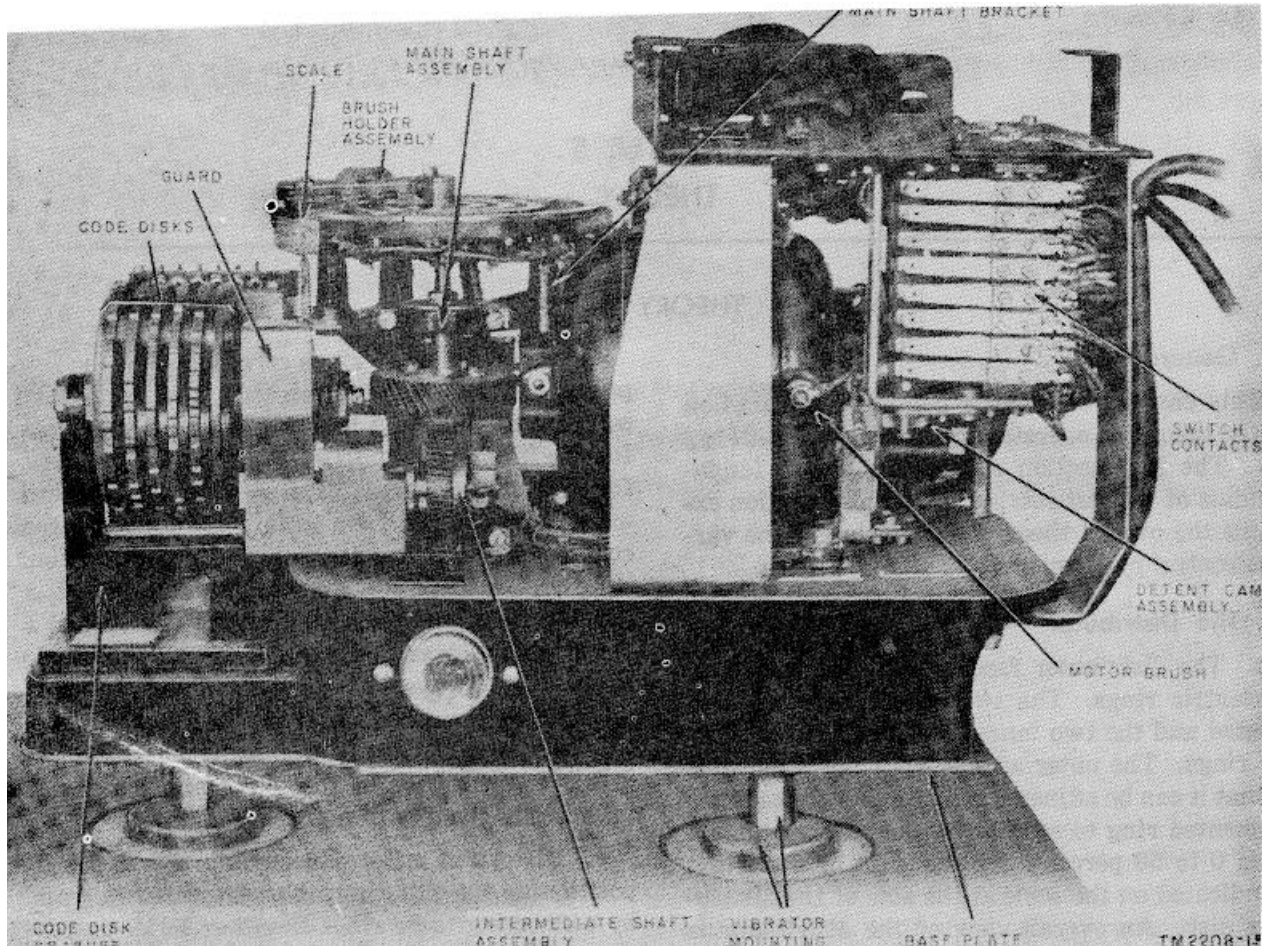

Figure 21. Distributor and main shaft assemblies.

the tongues are forced up by the code disks, and they afford an electrical connection between the terminal block and the contact tongues. Thus, when the tongues are in the lower position, an electrical connection exists from the terminal block, through the contact tongues, and through the lower contacts to the character selecting switch.

c. The five code disks (fig. 22) contain cams of various lengths spaced around their outer rims. The disks are bolted together and rotate with a fixed relationship to the rotation of the distributor brush arm. A friction assembly, located at the end of the code disk cam assembly, applies a drag on the shaft and prevents backlash. The five contact levers have pointed arms which press against the coded disks. As a contact lever rides up on a raised cam, it is forced to pivot about the contact lever bearing shaft, raising the contact tongue against the upper (spacing) contact and thus transmitting a space (no current) impulse. When the contact lever rides into a low position of the coded disk the contact tongue is pulled down to the lower (marking) contact, transmitting a mark (current) impulse. The coded disks are so arranged that at any one position, the five contact levers hold the contact tongues in the positions necessary to transmit marking and spacing impulses in the correct sequence to form a complete character or function in accordance with the teletypewriter 5-unit start-stop code. One complete revolution of the code disks on Test Sets TS-2 TG and TS-2A TG transmits the test message THE QUICK BROWN FOX JUMPED OVER A LAZY DOG'S BACK 1234567890 TESTING, followed by one carriage return and two line feed combinations. One complete revolution

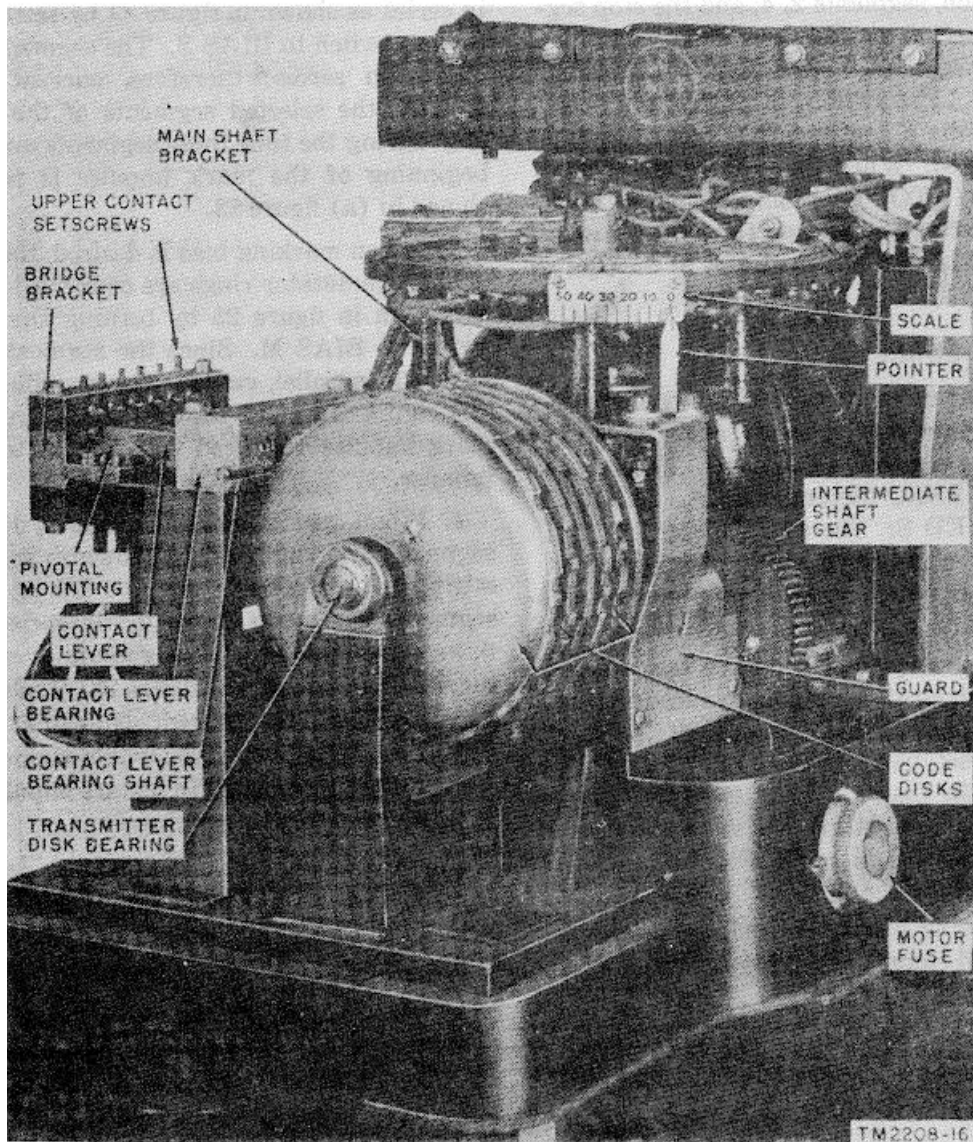

Figure 22. Code disk and contact lever assemblies.

of the code disks on Test Sets TS-2B TG transmits the same test message followed by four letters combinations, two carriage return combinations, one line feed combination and one letters combination.

d. The electrical circuit from the distributor through the transmitting contacts to the signal line is completed by setting the character selecting switch in the TEST MSG position. When the character selecting switch is in any other position, the transmitting contacts are open and the test message is not transmitted to the signal line

Section II. CONTROL MECHANISMS

61. Character Selecting Switch

The character selecting switch is a 6-pole, 5- position switch. The positions are: R, Y, TEST MSG, RPT SP, and STOP. In the TEST MSG position, the character selecting switch connects the code disk transmitter to the signal line. In the R, Y, and RPT SP positions, the switch disconnects the code disk transmitter from the signal line and connects the distributor ring's in the correct sequence to the signal line. With the switch

in the R position, segments 2, 4, and the stop segment are connected to the signal line. With the switch on Y, segments 1, 3, 5, and the stop segment are used. The switch, in any of the above positions, permits a continuous selected function to be transmitted. When the character selecting switch is in the STOP position, the signal line is shorted, preventing any signals from being transmitted but providing a closed circuit to the equipment under test.

62. Distortion Switch

a. The distortion switch is a system of make break spring contacts which are ganged together and operated by a bakelite camshaft. The switch may be set for ZERO distortion, BIAS M, BIAS S, ED M, and ED S. The selections are defined by a detent roller and lever which presses against a detent cam mounted on the lower end of the bakelite camshaft.

b. When bias is provided by the test set, all *space-to-mark* transitions are advanced or retarded with regard to the beginning of the start impulse of a teletypewriter character. End distortion differs in that all *mark-to-space* transitions are advanced or retarded with regard to the beginning of the start impulse. Figure 23 shows examples of distorted signals.

c. When spacing bias is desired, the segments of the segmented commutator rings are connected in series as shown in figure 24 by setting the distortion switch to BIAS S. The segments are connected in series; therefore, current will flow through the selected segments of the two rings only during the time these segments overlap. The beginning of the mark impulse is retarded as shown in (a) figure 23.

d. When marking bias is desired, the segments of the commutator rings are connected in parallel as shown in figure 25 by turning the distortion switch to BIAS M. Since the segments are connected in parallel, current flows as illustrated in (b) figure 23. This shows the beginning of the mark impulse advanced with regard to the start impulse.

e. When spacing end distortion is desired, the segments are connected as shown in figure 26 by setting the distortion switch to ED S. Since the segments are again connected in series, current flows when the selected segments overlap, with the result shown in (c) figure 23. The end of the mark impulse is advanced. Note that the start and stop segments of the movable segmented ring are connected, resulting in a start impulse always equal to a unit length impulse.

f. When marking end distortion is desired, the segments are connected as shown in figure 27 by setting the distortion switch to ED M. Note that in this case, only one movable stop segment is used

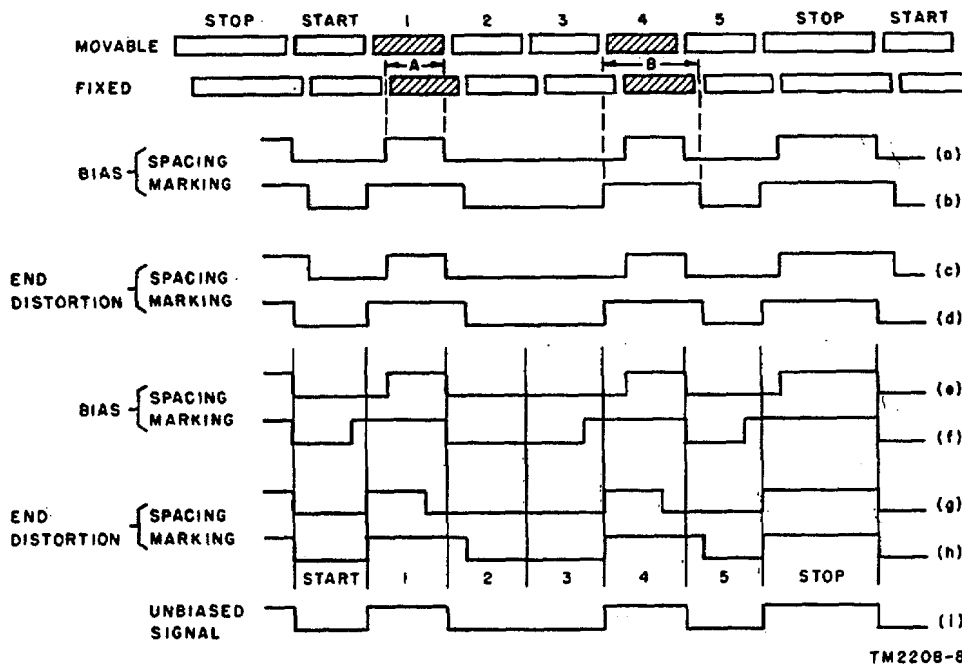

Figure 23. Examples of distorted signals.

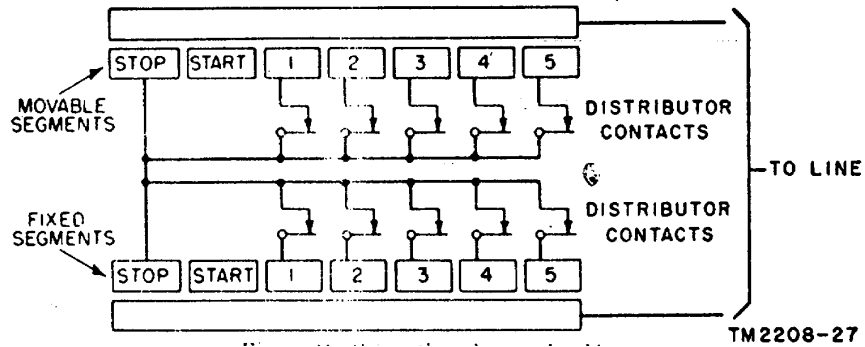

Figure 24. Connections for spacing bias

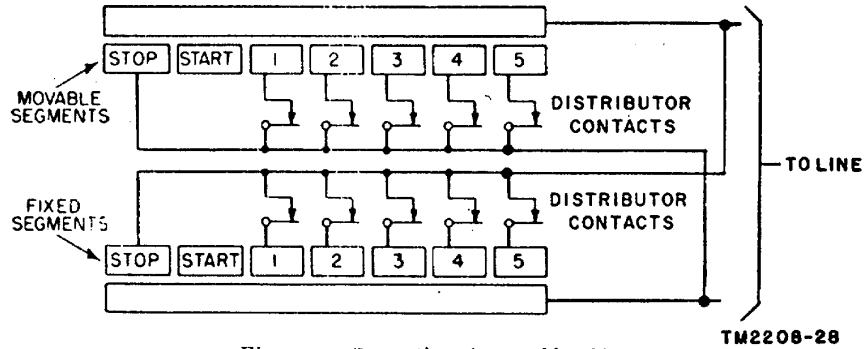

Figure 25. Connections for marking bias.

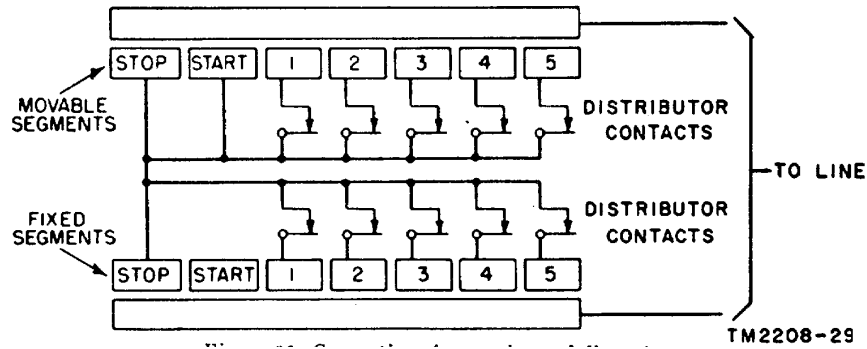

Figure 26. Connections for spacing and distortion

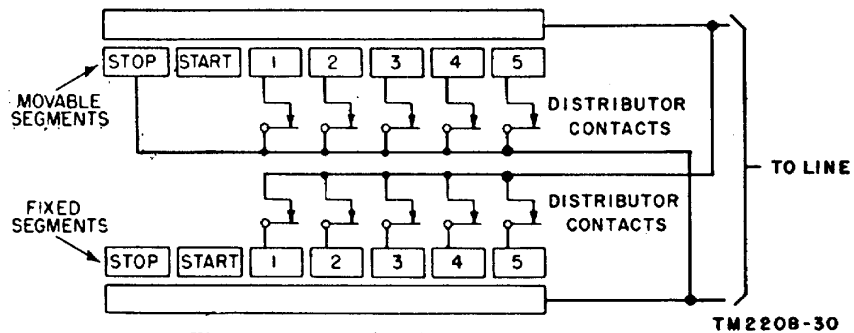

Figure 27. Connections for marking and distortion.

and that the several selecting segments are connected in parallel. The resultant current flow is shown in (d) figure 23. The end of the marking impulse is delayed.

g. Signal traces (a), (b), (c), and (d) in figure 23 have been re-drawn and are shown as traces (e), (f), (g), and (h). The latter four traces are identical with the former except that the beginning of the start impulses are brought into line with each other to illustrate the manner in which the signals appear to a start-stop receiving selector mechanism.

h. Unbiased signals are obtained from the fixed segmented ring and its associated continuous ring by setting the distortion switch to ZERO. The resultant current impulse is shown in (i) figure 23.

63. Motor Governor

A governor is used on series motors to maintain proper operating speed. It consists essentially of a pair of centrifugally controlled contacts which shunt a resistor in the motor circuit. When the motor is not running, the contacts are closed and a low-resistance path is connected across the terminals of the governor resistor. When the motor is connected to the power supply and power is applied, the armature begins to turn. Its speed increases until the centrifugal force causes the governor contacts to open. The speed at which the contacts just open is called the critical speed. The opening of the contacts removes the low-resistance path across the governor resistor. This increases the resistance of the motor circuit, reduces the current through the motor and causes a drop in the motor speed. When the speed has dropped below the critical speed, the contacts close and the cycle repeats. The contacts open and close several times a second, producing an average speed that is almost constant. The critical speed can be changed by varying the tension of the governor contact spring by turning the speed adjusting wheel. This method of changing the critical speed provides the means of obtaining the correct average speed of the motor.

CHAPTER 6

FIELD MAINTENANCE INSTRUCTIONS

Note. This chapter contains information pertinent to field maintenance. The amount of repair that can be performed by units having field maintenance responsibility is limited only by the tools and test equipment available and the skill of the repairman.

Section I. GENERAL TROUBLESHOOTING TECHNIQUES

64. General

a. A thorough knowledge of the functioning of each unit of the test set is of fundamental importance in analyzing trouble. The maintenance man must be able to determine quickly whether the trouble is due to a mechanical failure within a specific part of the equipment or whether the trouble is in some electrical circuit. The appearance of a particular operating failure may immediately indicate the exact location of the faulty adjustment or damage. If it does not, the maintenance man must determine exactly what parts are functioning properly and what parts fail to do so.

b. The isolation of trouble can usually be accomplished quickly by the process of elimination. If the test set, when connected into a circuit which was previously known to be in good operating condition, fails to give satisfactory service, the trouble is probably in the test set itself.

Caution: Do not take the test set apart or make readjustments until it is certain that the equipment is faulty.

c. When it has been reasonably established that the trouble is within the test set, the next step is to localize the trouble to a particular electrical circuit or mechanical element. The troubleshooting chart (par. 67) gives the most common troubles and the probable causes. Use this chart as a reference when locating trouble.

65. Localizing Electrical Troubles

All electrical circuits are wired to terminal blocks mounted on the under side of the base casting from where they are taken by cords and plugs to their external destination. The localization of trouble in the circuits is discussed in the following subparagraphs.

a. *Code Disk Transmitter Circuit.* The probability of trouble in the code disk transmitter circuit is always present, but it is a trouble which can be readily isolated. The code disk transmitter circuit operates only when the character selecting switch is in the TEST MISG position. Therefore, when trouble arises, the transmitter can be isolated by merely turning the character selecting switch to R or Y. If trouble persists, it is not in the code disk transmitter circuit.

- (1) An open in any lead from the code disk transmitter causes the impulse to be transmitted as a spacing impulse, that is, a no-current impulse. This causes a partial garbling of the transmitted message.
- (2) An open in the distortion control circuit may cause a no-current impulse to be sent out. It may also have the effect of sending out an undistorted signal when the distortion control switch is set for a distorted signal.
- (3) A short in two leads from the code disk transmitter circuit causes a marking impulse to be transmitted at a point when one is not desired. It has the same result as though two segments of the distributor were shorted.

b. *Control and Distributor Circuits.* The various circuits are selected for operation by the character selecting switch. This switch changes the electrical circuit in such a manner as to select the desired signal for transmission.

- (1) An open in any of the leads from the

character selecting switch causes a spacing impulse to be transmitted, thereby garbling the transmitted signal. In like

manner, a short between any of the leads causes an erroneous marking impulse to be transmitted. This short can be localized by switching to the various signals.

- (2) The most common electrical troubles caused by the distributor are excessive sparking and shorts between the brushes. Metal and carbon particles occasionally accumulate between the ends of the segments and between the concentric rings. If the accumulation becomes great enough to short the segments, false impulses are transmitted. If the concentric rings are shorted, a steady marking signal is transmitted. Excessive sparking of the distributor brushes usually is caused by brushes that are worn or improperly seated. Excessive sparking causes irregularities of the marking impulse.

c. *Motor Circuit.* Motor circuit troubles depend upon the type of motor used. The most common trouble is caused by worn or dirty motor brushes or by worn, burned, or shorted governor contacts.

66. Localizing Mechanical Troubles

Mechanical faults may develop in the test sets, but little trouble should be experienced in localizing them if the logical sequence of checks outlined in the following subparagraphs is followed.

a. *Code Disk Transmitting Assembly.* After the set has been running a few minutes, set the character selecting switch to TEST MSG. If the signal shows signs of garble or erroneous space impulses, turn the selecting switch to another character. If trouble no longer exists, the trouble probably lies somewhere in the code disk transmitting assembly. To correct the trouble, refer to paragraphs 47 and 48 for the proper adjustment of transmitter contact levers and tongues.

b. *Distributor.* If errors continue to be transmitted on all settings of the character selecting switch, a fault in the distributor is indicated. A poorly adjusted commutator brush or pits on the commutator caused by arcing will cause spasmodic errors in the transmitted signal. Consistent errors in a II settings may indicate that the distributor is not properly adjusted to transmit ZERO distortion. Correct these errors by proper adjustment according to instructions given in paragraphs 49 and 50.

c. *Controls.*

- (1) *Character selecting switch.* Turn the character selecting knob to the various signals. If characters other than those selected are transmitted, the character selecting switch is at fault. Excluding trouble in the electrical circuit, the fault is probably caused by open or dirty contacts or an improperly adjusted knob.
- (2) *Distortion.* If distortion is present when the distortion knob is set at ZERO or if no distortion can be obtained by turning the distortion knob, the trouble is caused by dirty, pitted, or improperly adjusted contacts. The distortion switch should be adjusted in accordance with the requirements in paragraphs 53 through 57. The detent cam or distortion knob also may be out of adjustment:

d. *Motor and Governor.* If the test set seems to run too fast or too slow or if there is a marked fluctuation in the speed, the governor assembly requires adjustment. Check the adjustments with the requirements given in paragraphs 38 through 42. Weak or poorly adjusted governor springs or pitted or dirty contacts will cause this trouble. Make adjustments according to instructions in paragraph 40.

67. Troubleshooting Chart

The most common troubles that occur in these test sets, together with a listing of the probable causes and the corrective action, are given in the following chart. This list of troubles does not represent all the troubles that might occur or all the probable causes for each condition, but does include those which occur in the majority of cases. The probable causes or the items in which the causes may be found are listed under each heading. The references include (I after the corrective action furnish a cross-reference to paragraphs in other sections of this manual.

Condition	Probable trouble	Corrective action
Motor fails to start-----	Ac power cord not plugged in----- Burned-out motor fuse----- Power switch inoperative----- Motor brushes dirty or inoperative--	Plug in ac power cord. Replace fuse. Clean or replace switch. Clean or replace brushes (pars. 80 and 81).
Motor runs too fast or too slow. Governor cannot be adjusted.	Open connection in power cord--- Governor contacts dirty or inoperative. Governor brushes and contact disks dirty or inoperative.	Repair connection or replace cord. Adjust contacts (pars. 38 and 39) or clean or replace (pars. 87-90). Clean or adjust (pars. 40-42) brushes and disks.
Transmits garbled test message----	Dirty or inoperative transmitting contacts. Code disk phasing out of adjustment Open in leads to transmitting contacts. Shorted leads to transmitting contacts.	Clean or adjust (pars. 47 and 48) contacts. Phase code disks (par. 51). Repair open. Remove short.
Sends garbled signals in all positions of character selecting switch.	Distributor segments shorted----- Shorted wiring or leads from coding unit assembly. Improperly adjusted distributor brushes.	Remove short. Remove short. Adjust brushes (pars. 49 and 50).
Transmits characters other than those indicated by character selecting switch.	Character selecting knob positioned improperly on shaft. Short or open in wiring or leads from coding unit assembly Improperly adjusted distributor brushes.	Reposition knob. Remove short or repair open. Adjust brushes (pars. 49 and 50).
Transmits garbled signals in one position of character selecting switch.	Open lead in circuit for that position Shorted lead in circuit for that position.	Repair open. Remove short.
Transmits spasmodically erroneous marking impulses.	Distributor segments dirty or shorted Grounded lead in distributor circuit Short in leads to distortion switch contacts.	Clean segments (par. 75) or locate short and remove. Remove ground. Remove short.
Distortion cannot be obtained or is present at all times.	Distributor brushes shorted Improperly adjusted distributor brushes. Transmitting commutator rings shorted. Short in leads to distortion switch contacts.	Remove short. Adjust brushes (pars. 49 and 50). Remove short. Remove short.
Amount of distortion cannot be increased or decreased.	Open in leads to distortion switch contacts. Distortion control switch improperly adjusted or worn. Weak or poorly adjusted springs in distortion switch.	Repair open. Adjust switch (par. 53) or replace (par. 94) . Adjust springs (pars. 54-57) or replace switch (par. 94).
Runs properly but fails to transmit signals.	Open or short in leads from distributor disk. Open in line cord Open connection on terminal block Shorted capacitor in filter switch Improperly adjusted distributor brushes.	Repair open or remove short. Repair or replace cord. Resolder connection. Replace capacitor. Adjust brushes (pars. 49 and 50).
Local test circuit inoperative-----	Open in local test jack----- Short in local test jack----- Open resistor in test jack circuit--- Open in local test circuit cord-----	Repair open. Remove short. Repair open or replace resistor. Repair or replace cord.

Section II. REMOVAL AND REPLACEMENT

68. General

Most assemblies of Test Set T'S-2(*) /TG should be removed from the base before they are dismantled for repairs. This section describes the recommended procedure for removing, repairing and replacing defective parts of the test set. It does not duplicate information on preventive maintenance contained in chapter 4. Except in cases of extreme emergency, all repairs should be completed by personnel thoroughly trained in teletypewriter maintenance.

69. Removal and Replacement of Motor

- a. Remove the motor from the base for all repairs except replacement of motor brushes.
 - (1) Remove the test set from the wooden chest base.
 - (2) Remove the motor pinion guard.
 - (3) Loosen and lay aside the control panel. Be careful not to crack or damage any insulation or pull apart any connections.
 - (4) Unscrew, or untape any motor leads and clip any waxed string or other lacing which holds the wiring to the base. The governor and motor pinion gear need not be removed until the motor has been taken off the base.
 - (5) Carefully slide out the governor brush bracket assembly and motor governor filter assembly and lay them to one side.
 - (6) Remove the four motor mounting bolts and carefully work the motor from the base.
- b. Replace the motor on the base by reversing the procedures outlined above.

70. Removal and Replacement of Main Shaft

- a. Remove the main shaft as follows:
 - (1) Remove the brush holder assembly from the main shaft. The screw that holds the brush holder assembly on the main shaft is located on the shaft under the distributor disk.
 - (2) Loosen the clamping screw on the bakelite gear on the intermediate shaft and slide the gear off the end of the intermediate shaft.
 - (3) Remove the upper and lower bearing retaining caps.
 - (4) Lower the shaft so that it will clear the bottom of the distributor disk and swing the top end of the shaft clear of the disk.
 - (5) Ease the main shaft assembly out and upward.
- b. Replace the main shaft by reversing the procedures outlined above. Adjust the intermediate shaft bakelite gear according to instructions in paragraph 45.

71. Removal and Replacement of Contact Lever Bracket, Code Disk Bearing, and Intermediate Shaft Assemblies

- a. The contact lever bracket and the code disk bearing assemblies are mounted on a base which forms a part of the intermediate shaft assembly. This base, in turn, is fastened to the base of the test set with four screws located on the underside of the test set base.
 - (1) Remove the bottom plate of the test set to get at the four screws which secure the intermediate shaft base to the base of the test set. Be careful not to break or put any strain on the wiring to the contact lever bracket assembly.
 - (2) Remove the four screws which fasten the contact lever bracket assembly and the code disk bearing assembly to the intermediate shaft base.
- b. Replace the above assemblies by reversing the procedures outlined above.

72. Removal and Replacement of Character Selecting Switch

- a. Remove the bakelite knob by loosening the setscrew which holds the knob in place.
- b. Remove the mounting nut and gently work the switch out. Be careful not to damage any wiring.
- c. Unsolder the leads and tag them to facilitate connecting the new switch.
- d. Replace the switch, following in reverse order, the procedure for removal.

Section III. REPAIRS

73. Cleaning Procedure for Major Overhaul

a. *General.* Equipment that has been disassembled for major overhaul can be cleaned by immersing or brushing the mechanical parts in vats of appropriate cleaning material or by wiping the parts thoroughly with a cloth dampened with appropriate cleaning material.

Caution: Do not immerse, brush excessively, or dampen motor windings and armatures, equipment, wiring, capacitors, and resistors.

b. *Materials.*

(1) *Cleaning Compound, liquid form.* Use Cleaning Compound, liquid form (Federal stock No. 7930-395-9542) to remove oil, grease, gummy deposits, and small amounts of soluble materials such as dirt, dust, mud, paper, and lint. Do not use on rubber products. After using Cleaning Compound, wipe the equipment dry so that no film or residue is left when the Cleaning Compound dries.

(2) *Water.* Use water only to remove excessive amounts of mud, dirt, or other soluble foreign materials from the exterior of the chest. **Caution:** Do not allow water to dampen the motor windings and armature, equipment wiring, capacitors, or resistors.

c. *Drying.*

(1) *Wiping.* Wipe smooth-surfaced parts with a clean, dry cloth until they are dry. Be sure that all crevices and corners are dry.

(2) *Oven.* If possible, dry all parts that have been washed or flushed with water in an oven or under heat lamps for 1 to 2 hours at 160° F.

(3) *Air blast.* Parts that have been washed with water or Cleaning Compound may be dried by using an air blast. Dry all parts thoroughly. **Warning:** Be careful when drying parts with an air blast to prevent loss of parts or serious injury to personnel from flying parts.

74. Main Shaft Repairs

(fig. 11)

Repairs on the main shaft consist principally of replacement of parts. Before any repairs can be made on the main shaft it must be removed (par. 70) from the test set. The main shaft should be disassembled as follows:

a. Remove the upper and lower ball bearings by taking off the nut and lockwasher which hold them in place. Remove the bearing covers.

b. Remove the main shaft pinion gear by loosening the setscrew in the hub and slipping the pinion gear off.

c. Remove the main shaft gear by unscrewing the screws which hold it to the main shaft hub.

d. The main shaft hub is pressed on the shaft and secured by a pin. For most repairs the main shaft hub need not be removed.

e. Reassemble the main shaft by reversing the procedures outlined above.

75. Refinishing Distributor Disk

a. Loosen the brush holder arm retaining screw and remove the brush holder assembly. Wrap a piece of cheesecloth or other cloth around the main shaft and the code disk transmitter below the distributor disk to protect them from metal particles and grit.

b. Wrap a piece of No. 000 sandpaper around a block of soft wood with dimensions of about 2 by 5 by 3/4 inches. Place the block on the distributor disk and press down with the fingers. Rotate the block about the axis of the main shaft, avoiding undue pressure on any one point. As soon as the segments are almost smooth, remove the No. 000 sandpaper and replace it with No. 0000 sandpaper. Repeat the finishing process until the segments are smooth and polished. Do not remove any more metal than is necessary. Remove any dust or metal particles which may have accumulated between the segments.

c. Carbon particles from carbon brushes become imbedded in the surface of the copper commutator segments, causing them to become dark. The discoloration is a form of case-hardening and greatly increases the life of the segments. Do not remove this discoloration unless the segments are deeply grooved.

d. After refinishing the distributor, trim off any burrs that may have formed on the ends of the segments. These burrs cause the carbon brushes to chip. Coat the ends of the segments with a coat of insulating varnish to prevent carbon dust or copper particles from shorting the segments.

AGO 8686A

76. Disassembly of Motor for Repairs

a. *General.* Remove the motor from the base as directed in paragraph 69. Unsolder any leads so that the motor will be totally disconnected from the set. Label the leads to facilitate reconnection.

b. *Step-by-Step Disassembly of Motor in Test Set TS-2/TG.*

- (1) Remove the motor pinion gear and the governor. Be careful not to lose any of the shims that may be on the armature shaft between the governor and the end of the frame casting of the motor.
- (2) Remove the brush holder caps and the brushes.
- (3) Remove any external bearing retainer screws.
- (4) Remove the motor bolts and take off the end bell by prying gently with the blade of a screwdriver. Lift out the armature. Be careful not to drop the armature or damage the windings. Do not lose any of the parts such as bearing retainers, springs, or washers.
- (5) Remove the armature bearings with a suitable bearing puller.

c. *Step-by-Step Disassembly of Motors in Test Sets TS-2A/TG and TS-2B/TG.*

- (1) Remove the motor pinion gear and the governor.
- (2) Remove the brush holder caps and remove the brush and spring assemblies.
- (3) Remove the two screws on the plain end of the motor. This will allow the motor to be pulled apart and the armature removed. Be careful not to drop the armature or damage the windings. Do not lose the tension washer located under the armature bearing.
- (4) Remove the armature bearing with a suitable bearing puller.

Caution: Be careful when using a bearing puller on bearings which have built-in dust shields. Position the puller so that it presses on the outer bearing race *only*. Pressure exerted on the dust shield will crumple the shield and destroy the bearings. *Do not attempt to pull the bearings off with a screw driver.*

77. Special Cleaning Instructions for Motor

The instructions given in this paragraph are for cleaning the internal parts of the motor.

a. Disassemble the motor (par. 76).

b. Remove all dust, paper lint, nonoily dirt, etc., from the armature and stator windings by brushing carefully with a clean, dry sash brush. *Do not damage the windings.'*

c. Remove all oil, grease, or gummy deposits from the face of the armature and stator by wiping them with a piece of cheesecloth, dampened with Cleaning Compound. *Do not use too much Cleaning Compound.*

d. Clean the end frames, bearings, motor pinion gear, and any other metal parts by immersion in a container of the appropriate cleaning fluid. Be sure to dry and lubricate the parts as directed.

e. Remove all dust, dirt, oil, grease, gummy deposits, or other foreign matter from the commutator by rubbing it with a piece of cheesecloth dampened with Cleaning Compound. Be careful not to damage the windings. The copper segments of the commutator may become quite dark and discolored. *Do not* polish the commutator to remove this discoloration unless the commutator has become so deeply grooved, or unless it causes such excessive sparking at the brushes, as to require being turned down on a lathe. When the armature requires such action, it should be replaced and the old armature returned to supply or qualified armature repair personnel.

78. Replacement or Repair of Motor Armature

a. After long periods of operation, the commutators of series-wound motors become worn and grooved by brush wear, and they require resurfacing. If the surface of the commutator is not deeply grooved and has an even, smooth, grayish coating of oxide, resurfacing is not required unless there is excessive sparking at the brushes when the motor is under load.

b. If there is excessive sparking of brushes on a commutator that is not grooved or pitted, clean it with a cloth moistened with Cleaning Compound, turning the shaft over by hand after the brushes are removed, as described in paragraph 80.

AGO 8686A

c. If there is still excessive sparking, remove the armature from the motor and clean the commutator by lightly applying No. 0000 sandpaper. To do this, wrap a piece of sandpaper around the commutator and rotate the armature, holding the sandpaper against the rotating commutator very lightly.

d. Inspect the commutator carefully to determine if it is necessary to undercut the separating insulators between the segments (par. 79). The top of the insulating material must be below the level of the commutator bars on either side. This is necessary to prevent small carbon particles from lodging in the separators and building up to a point where the adjoining commutator segments or bars will be short-circuited.

79. Undercutting Commutator Bar Separators (Insulators)

Tool equipments available at larger repair shops may include any one of several types of undercutting tools. Do not attempt to use such tools until the directions furnished with them have been carefully studied. If no standard undercutting tool is available, improvise a substitute from a piece of hacksaw blade, as follows:

a. Grind the sides of the cutting edge of the hacksaw blade until the total width of the teeth is a little less than the width of the slot between the commutator segments.

b. Fit a wooden handle to the ungrounded portion of the blade to protect the fingers against injury.

c. Hold the improvised tool at an angle so that only one or two teeth are in contact with the separator material, which is usually mica. Draw the tool in a direction away from the windings and cut away a portion of the separator. Repeat the process until the surface of the separator material is a maximum of one sixty-fourth inch below the surface of the adjacent metal commutator segment bars, uniformly, along the entire slot. Repeat for all the separator slots in the commutator. *Be sure that there are no slivers of metal remaining in the slots after the cutting process.* Such slivers will short-circuit the commutator segments and burn out the windings when the motor is started.

80. Replacing Motor Brushes

a. When removing the brushes, mark the upper surface so that the brush may be replaced in the same holder with the same side uppermost. If the brush has a number stamped on the upper side of the carbon, this number may be used as a guide.

b. Inspect the brushes as follows:

(1) See that at least five-eighths inch of brush material remains.

(2) Be sure that at least one-third of the brush face bears upon the commutator surface.

(3) See that the brushes make contact across at least 75 percent of the long dimension of the brush face.

c. If the above requirements are not met, replace it with a new brush.

81. Surfacing and Installing Motor Brushes

To shape the contact face of the brush to the curvature of the commutator, proceed as follows:

a. Wrap a piece of No. 0000 sandpaper around the commutator under the brush holder with the abrasive side away from the commutator face.

b. Insert the brush in the brush holder with the numbered or marked side uppermost, so that the brush bears against the sandpaper under the normal pressure of the brush spring.

c. Rotate the armature back and forth by hand, so that the sandpaper will wear a surface of proper curvature in the contact face of the brush. The last rotation of the armature should lie in the direction in which it would turn during operation of the motor.

d. After the proper curvature has been cut in the brush face, remove the brush from the brush holder. Bevel the edges, slightly, with sandpaper.

e. Wipe the brush with a cloth moistened with Cleaning Compound.

f. Examine the brush spring to see that it is in good condition. See that the pigtail within the brush spring is intact and free from kinks, and that it will permit the spring to extend properly.

g. Clean out the brush holder with a piece of cloth moistened with Cleaning Compound wrapped around a stick, or an appropriately shaped tool such as a screwdriver. Be careful not to score the sides of the brush holder.

AGO 8686A

h. Reinsert old brushes in brush in brush holders from which they were removed for resurfacing. See that the brush is restored in the same position that it occupied before removal.

i. Always insert a new brush that has just been resurfaced with the numbered side uppermost.

j. See that the brush moves freely in the brush holder. Check the pressure of the brush springs and see that they meet the specified requirements.

82. Replacing Armature Bearings

a. *General.* Install new bearings if those in use are burned, cracked, badly worn, or damaged in any way. Handle the bearings carefully. See that no dirt gets into the bearings races. Except on Test Sets TS-2A/TG and TS-2B/TG, lubricated all bearings including used bearings that are found to be in good condition when cleaned and inspected. Apply grease, Signal Corps stock No. 6G650, to new bearings before they are installed on the shaft. In addition to its lubricating properties, the grease prevents dirt from entering the bearings. Place a paper washer over the exposed side of the bearing to further prevent dirt or dust from entering. The motors in Test Sets TS-2A/TG and TS-2B/TG are equipped with factory-greased and sealed bearings and will not require further lubrication.

b. *Installation of Bearings.* The following procedure outlines a typical method installing bearings on the armature shaft.

(1) *General.* Bearings fit tightly upon the armature shaft. Therefore, they must be pressed onto the shaft with an arbor press, vise, or similar tool. Such tools are normally available at field repair shops. It is important to see that the bearings is pressed onto each end of the shaft carefully, so that the pressure exerted by the press or vise will not bend armature shaft or force the bearing on the shaft at an angle to the axis of the shaft.

(2) *Preparatory.* Prepare two blocks of hardwood, equal in length and about 1 inch longer than the armature shaft extension. Shape on end of each block so that it will no bear against the ball bearing or outer race of the bearing. Prepare another block (fig. 28) large enough to be used against the rear jaw of the press or vise. Slip a bearing onto each end of the shaft as far as it will go, fingertight.

(3) *Installing*

(a) If the bearings have dust covers see that dust cover of each bearing is nearest the winding. Place the two wooden blocks of equal length at either side of the armature shaft extension (fig. 28). Place the other block of wood against the rear jaw of the press or vise. See that the armature is set in the press or vise so that end of the armature shaft is near the center of the face of each jaw. Tighten the tool very slowly until there is even pressure applied to both sides of the bearing. Be careful not to bend the armature shaft. Continue to slowly tighten the tool until the bearing is pressed onto the shaft and is against the armature shaft shoulder (fig. 28). Repeat the procedure to mount the bearing on the opposite end of the shaft. Some types of bearings can be taken apart. If possible, disassemble and assemble this type of bearing on the shaft. The inner race can then be removed and replaced on the shaft with less danger of damage to the other parts of the bearing.

(b) When a suitable press or vise is not available, bearings can be installed on the armature shaft, when authorized as a field expedient, by the following method.

1. Slide the bearings on the armature shaft as described in (2) above.

2. Prepare a piece of copper or brass pipe 1 inch longer than the shaft extension (fig. 29) with an inside diameter slightly larger than the diameter of the diameter of the armature shaft. If copper or brass pipe is not available, and iron pipe can be substituted, provided a brass washer is used to protect the inner race of the bearing against the iron pipe. Slip the copper or brass pipe onto the shaft so that it bears against the inner bearing race.

3. Stand the armature on end with the pipe resting on the bench or work table.
 4. Place a block of hardwood over the other end of the armature shaft. Drive the armature shaft down by pounding the upper end of the armature shaft (protected by the hardwood block) with a hammer (fig. 29). Use steady, even strokes of the hammer until the bearing is forced firmly against the shoulder of the shaft.
- Caution:** Make certain that the pipe bears against the inner bearing race. Do not bend or otherwise damage the armature shaft.

83. Reassembly of Motor

a. Preparation. Thoroughly clean and dry the motor before reassembling. Examine the bearings and parts, which should be free from dirt before beginning to reassemble the motor.

b. Step-by-Step Reassembly.

- (1) Remove the brushes if they are still in the end frame section that fits over the commutator.
- (2) Position the bearing retainer so that the holes match the positions of the retainer screws.
- (3) Insert the armature into the stator so that the bearing on the shaft, opposite the commutator end, enters the end frame section. Do not use force because the bearing should fit easily into the end frame section.
- (4) Place the end frame section on the commutator end of the shaft. Gently tap the end frames into position.
- (5) Insert the motor frame bolts. Tighten the opposite ends at the same time to be sure that the end frame sections are mounted correctly and seated in the motor frame.
- (6) Use a toothpick, piece of wire, or any other convenient means to move the bearing retainer ring into position so that the bearing retainer screws can be started. Tighten both retainer screws at the same time.
- (7) Replace the motor pinion gear and the governor.

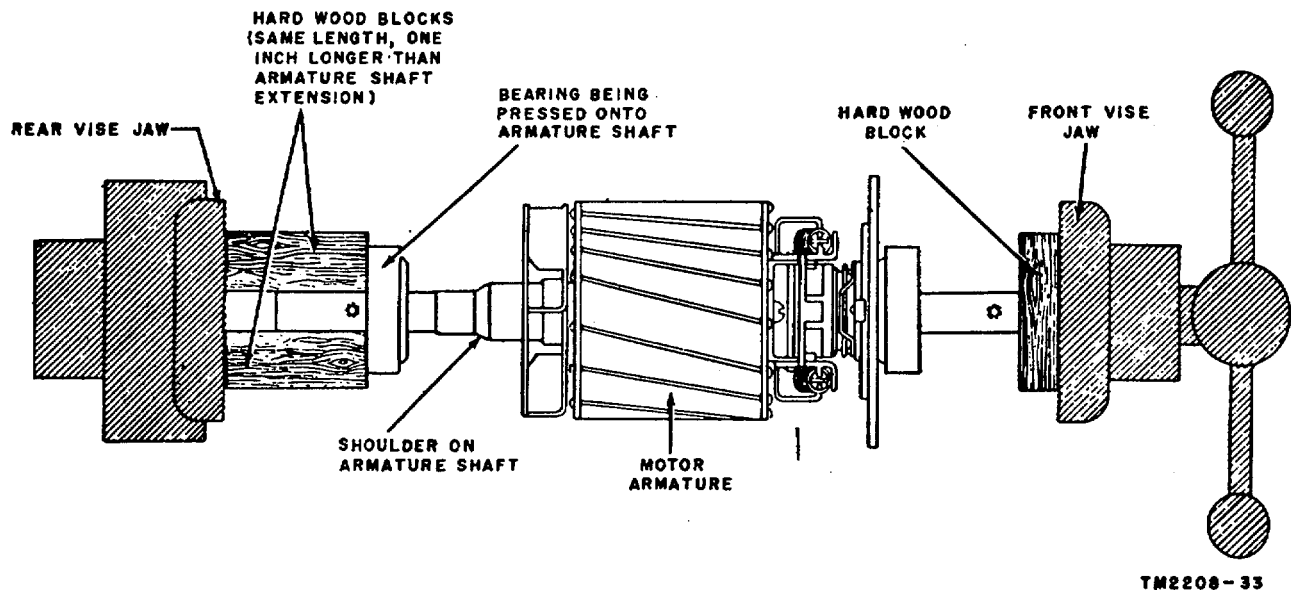

Figure 28. Pressing armature bearing onto its shaft by use of a vise.

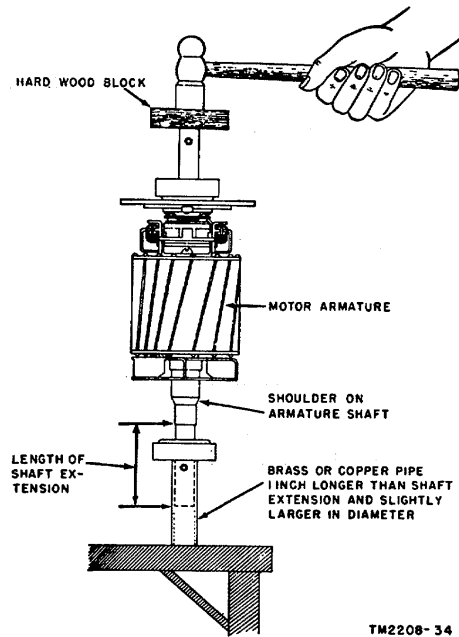

Figure 29. Mounting bearing on the armature shaft by use of hammer and soft metal pipe.

84. Motor Armature Thrust Spring Compression (fig. 12)

a. *Requirement.* Apply the push end of a 12-pound scale horizontally against the governor outer contact disk and push toward the pinion end of the motor. A push of at least 7 pounds should be required to start to overcome the compression of the armature spring.

b. *Adjustment.* If the spring does not meet the above requirement, replace with a new spring.

85. Governor Repairs

a. *General.* Governor contacts cause considerable trouble when they are not in good condition. All governor contacts in good condition have an overall grayish appearance. When the contacts have become pitted, or the grayish color does not cover 75 percent of the contact surface area, replace *both* contacts with new ones (pars. 87 and 88). Always replace governor contacts in pairs. Never touch the contacting surface with the fingers because even very small deposits of moisture or dirt will cause arcing and pitting.

b. *Contacts in Satisfactory Condition.* The ideal condition for governor contacts is when both contact surfaces are exactly parallel and the area of contact is a maximum (A, fig. 30). However, contacts may be satisfactory under the condition that one contact has build-ups and the other has corresponding craters, provided that the craters will accept the build-up (A, fig. 30), and thus maintain contact over an acceptable area. Contacts in this condition are considered to be good and need not be replaced unless there is trouble in obtaining and maintaining proper motor speed.

c. *Common Causes of Contact Trouble.*

- (1) Trouble due to poor surface contact is frequently the result of a previous attempt to burnish or file contacts to produce better surfaces. In such cases the build-ups have been removed, with the result that the craters that still remain do not meet the renewed surface (B, fig. 30), thus reducing the amount of effective contact surface.
- (2) If the contacts are rotated or shifted in position, as shown in C, figure 30, the build-ups and craters will not match. This condition results in extremely erratic motor speed because practically all of the contacting surface has been lost.

86. Disassembly of Governor

When necessary to completely disassemble the governor, proceed as follows:

- a. Remove the two screws that mount the brush spring plate on the brush spring plate bracket (fig. 12) and move the brush spring plate to the right far enough to clear the edge of the governor.
- b. Remove the screw holding the governor on the motor shaft and slip off the governor.
- c. Remove the screws securing the target and governor cover. Remove the target and cover.
- d. Unhook the speed adjusting spring (fig. 13).
- e. Loosen the screw which clamps the feather spring to the end of the governor contact spring and lift the governor contact spring out of the governor shell.
- f. Remove the nut and lockwasher on the contact screw mounted on the fixed contact bracket and lift out the contact screw.

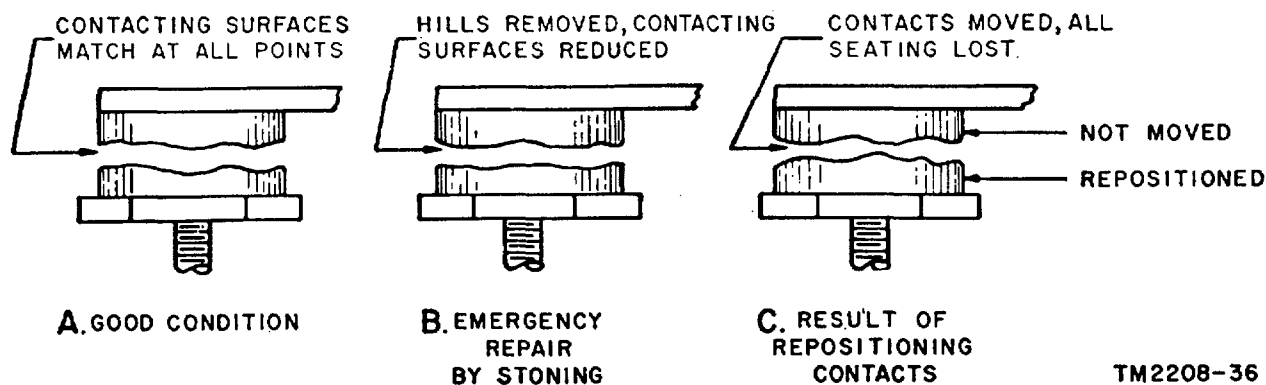

Figure 30. Governor contacts surfaces, enlarged diagrams.

87. Replacing Governor Contact Points

a. Contact points are made of tungsten. They are welded to the contact spring (Upper contact) and to the contact screw (lower contact). When removing the old contact points, replace both the upper and lower points at the same time to avoid difficulties in seating them.

b. Replace the new points with their associated contact springs and contact screws. The new lower point with a contact screw is properly aligned when the contact surface of the new point is perpendicular (or at right angles) to a line through the axis of the contact screw (A, fig. 31). The new upper point and contact spring is properly aligned when there is no appreciable gap between any part of the contacting surface of the new point and a straightedge (B, fig. 31).

Note. Old style contact springs had contact points that screwed into the spring and were bonded in position by a drop of solder on the spring or were soldered directly to the contact springs. New style contacts are welded and require replacement of upper spring and lower screw with contacts.

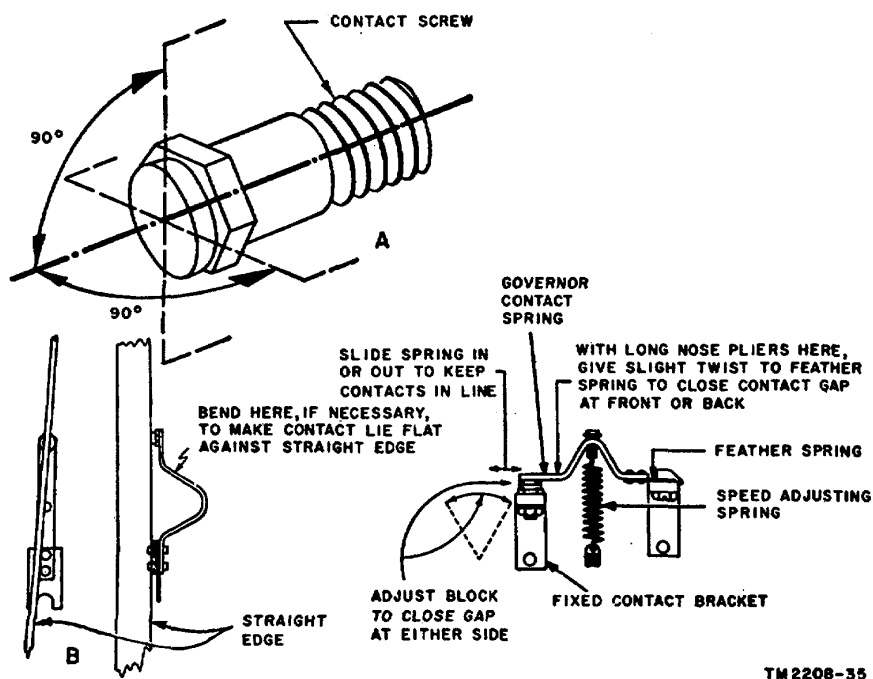

Figure 31. Alinement of new governor contact points.

88. Repair of Contact Points

In emergencies, when trouble is due to buildups or pitting and new contact points are not available, remove the points and dress them *very lightly* with a fine carborundum stone. Such a stone is part of Tool Equipment TE-50, TE-50-A, and TE-50-B. It may be necessary to remove a particularly large build-up by knocking it off with a screwdriver and then dressing the contact surface with the stone. When resurfacing a point with the stone, be careful to see that the stone is clean and has a level surface. Hold the point as flat as possible against the surface of the stone. To be sure that the entire face of the point is dressed level, use a rotary motion when dressing the contact point. In this way all parts of the face of the point will be dressed. Do not use too much pressure. Examine the point after every rotation. Stop when the face of the point meets the requirements mentioned in paragraphs 85b and 87b. Clean the dressed points with Cleaning Compound. *Replace both points as soon as possible. This is necessary to avoid trouble from build-ups and pitting, which for))l quickly on resurfaced contacts.*

89. Reassembling Governor

a. Insert the contact screw in the hole in the fixed contact bracket. Place the lockwasher and nut on the end of the contact screw. Tighten the nut securely.

b. Insert the feather spring of the contact spring assembly (fig. 31) under the clamp on its mounting block and tighten the clamp screw until the contact spring is held friction tight. The contacts should remain slightly separated (aprx. .005 in.).

c. Hook the speed adjusting spring onto the governor contact spring. Turn the speed adjusting wheel until all tension is released. Contacts should return to the slightly separated position indicated in b above.

d. Insert a piece of white paper behind the contacts.

e. Turn the speed adjusting wheel until the contacts just touch. Use a flashlight or other small bright light to illuminate the contacts during this adjustment.

f. Slide the governor contact spring to the right or left until the sides of the upper and lower contacts are aligned vertically. If a gap can be seen on either side of the contacts, loosen the fixed contact bracket retaining screw and move the top of the fixed contact bracket to the right or left. At the same time, shift the governor contact spring to keep the contact points in line. Tighten both the contact spring clamp screw and the fixed contact bracket retaining screw.

g. If a gap at the front or back of the contacts is observed, twist the feather spring on the end of the governor contact spring. Use a pair of longnosed pliers for the purpose. Repeat the above adjustments until the contacts are correctly positioned.

h. Turn the speed adjusting wheel so that the tension of the spring is near the midpoint of its range.

i. Clean the points with Cleaning Compound applied with a toothpick or an orange stick. Reassemble the governor cover and the target to the governor, and remount the governor on the motor.

90. Inspection, Cleaning, and Repair of Governor Contact Disks

a. Clean governor contact disks with a piece of cloth moistened with Cleaning Compound. A smooth, even, gray coating of oxide is desirable, and the contact disks should not be disturbed unless there is excessive sparking at the brushes.

b. To remove pits or burned spots from the contact surface of the disks use No. 0000 sandpaper. Hold the sandpaper against the disk surface by hand while the motor is running at normal speed. Hold a piece of cloth with the sandpaper in such a way, that cuttings and particles will be immediately wiped away during the sanding process.

c. Never touch the contact surface of the contact disks with the fingers. Very small deposits of foreign matter will cause arcing and pitting. It is good practice to flush the contacts with Cleaning Compound immediately after they have been polished. This can be done by repeatedly applying the fluid to the contact, by means of a toothpick or orange stick, to flush away all foreign matter, grease, or moisture. Be careful to prevent the Cleaning Compound from coming in contact with wire insulation or plastic parts.

91. Replacement of Inner and Outer Disk Contact Brushes

Replace the carbon contact brushes (fig. 12) on the inner and outer disk contact springs when the brushes are worn down to one-eighth inch. The carbon contact brushes and springs may be replaced as a unit or the carbon contact brushes may be replaced individually when it is not necessary to replace the entire brush assembly.

a. Replacing Carbon Contact Brushes and Springs as a Unit.

- (1) Loosen the screws that secure the spring and insulator pile-ups to the brush spring plate. It is not necessary to unscrew them completely as the springs have slotted ends and can be slid free of the brush spring plate.
- (2) Slide the new springs into the same position in the insulator pile-up. Adjust and position the new springs and carbon contact brushes according to instructions in paragraphs 41 and 42. Tighten the screws.

b. Replacing Carbon Contact Brushes.

- (1) Remove the carbon contact brushes and springs as directed in a (1) above.
- (2) Unsolder the old brush from the spring.
Clean off any solder that remains in the mounting hole in the spring from which the brush is removed.
- (3) Insert a new brush in the mounting hole and solder it securely in place. Clean the brush with Cleaning Compound applied with an orange stick or toothpick.
- (4) Replace the springs as directed in a(2) above.

92. Testing Repaired Governors

a. After the governor is completely reassembled, seat the new contacts by running the motor on test for at least an hour. Check the speed every 15 minutes and immediately investigate any change in motor speed..

b. If the motor speed is erratic and the trouble cannot be traced to other parts of the motor, disassemble the governor and check the contacts for build-ups and alignment. If build-ups are found, replace the contacts. After the contacts have been properly realigned, reassemble the governor and run the motor again for an hour.

c. Proper operation of the governor is indicated if the motor speed does not change appreciably during the hour test run.

93. Disassembly and Reassembly of Contact Lever Bracket

Note. After any parts on the contact lever bracket assembly have been replaced, make an overall adjustment of the test set.

The contact tongues and the upper and lower contacts may become pitted, broken, or otherwise damaged so that they require replacement.

a. Upper Contacts. To remove an upper contact, proceed as follows:

- (1) Remove the two screws that secure the upper insulator bridge to the bridge bracket.
- (2) Lift the insulator free and loosen the setscrew of the contact to be removed.
- (3) Remove the contact screw using an open-end or socket wrench of the correct size. Do not use a screwdriver in the slotted end of the contact screw for any purpose other than final adjustment of the contact gap. If the slot in the contact screw has been spread, burred, or damaged, file off such portions before removing the screw from the insulator to prevent damage to the thread in the insulator.
- (4) Reassemble in reverse procedure to disassembly. Adjust according to instructions in paragraph 47.

b. Lower Contacts. To remove a lower contact, proceed as follows:

- (1) Remove the screws that secure the lower insulator bridge to the bridge bracket.
- (2) While holding the insulator bridge clear of the bracket, loosen the setscrew and the terminal screw.
- (3) To remove the contact screws refer to a(3) above.
- (4) To reassemble the lower contact screws refer to a(4) above.

c. Contact Tongues. To remove a contact, proceed as follows:

- (1) Remove the four screws that secure the contact screw bridge assembly to the contact lever bracket.

- (2) Slide the bridge assembly clear of the contact lever bracket and the contact tongues.
- (3) Unsolder and remove the helical spring from the contact tongue.
- (4) Remove the two screws that secure the contact tongue and the insulators to the contact lever.
- (5) Reassemble in reverse procedure to disassembly. Adjust according to instructions in paragraph 47.

d. *Contact Levers.* To remove a contact lever, proceed as follows:

- (1) Remove the contact bridge assembly and the helical springs on the contact tongues.
- (2) Remove the two screws that secure the contact lever bearing to the contact lever bracket.
- (3) Remove the bearing with the contact levers from the contact lever bracket.
- (4) Loosen the two setscrews that hold the contact lever shaft in the bearing and slide the shaft out.
- (5) Remove the contact levers from the shaft.
- (6) Reassemble in reverse procedure to disassembly. Adjust according to instructions in paragraphs 47 and 48.

94. Disassembly and Reassembly of Distortion Switch Assembly

The distortion switch is easily accessible and is built of units. The individual contact spring assemblies and the detent assembly can be removed without disturbing or removing other parts.

a. *Detent Lever and Detent Cam.*

- (1) Remove the detent lever spring.
- (2) Remove the nut on the detent lever cam screw. The detent lever and the cam screw will then drop free.
- (3) Remove the setscrew in the detent cam and slide the cam off the shaft.
- (4) Reverse the above procedure for reassembly. Adjust in accordance with instructions in paragraphs 53 and

54.

b. *Contact Cam and Shaft.*

- (1) Remove the detent cam and loosen the setscrews in the bakelite cam sleeve. Pull the shaft out by the knob, and the bakelite cam will fall free.
- (2) Reassemble, following the disassembly procedure in reverse order. Adjust according to instructions in paragraph 53 and 55..

c. *Contact Spring Assemblies.*

- (1) Remove the mounting screws that pass through the insulator pile-up. Note the position and order of the springs and insulators in the pile-up.
- (2) Unsolder the leads and tag them to facilitate reconnection.
- (3) Reassemble; follow in reverse order the procedure used for disassembly. Adjust according to instructions in paragraph 57.

95. Cleaning Transmitting and Distortion Switch Contacts

a. *Changing Nonpitted Contacts..*

- (1) To clean nonpitted contacts, use a clean toothpick to flush the contacts with Cleaning Compound. Dip the flat end of the toothpick into the Cleaning Compound to a depth of about one-half inch, and deposit the liquid on the contacts without rubbing. Hold the contacts slightly separated during this operation.
- (2) Dip the flat end of another toothpick into the Cleaning Compound and deposit it on the contact, without rubbing, to flush away the dirt that was loosened on the first application. Be careful to keep the Cleaning Compound away from the insulators.
- (3) When the contacts are thoroughly dry, burnish them so that no deposit or residue from the solution or other foreign material remains on the contacts.

b. *Burnishing Contacts.*

- (1) Clean the contact burnishers before using by wiping with a clean, dry cloth, and wipe frequently with a clean cloth moistened with Cleaning Compound.
- (2) When burnishing normally open contacts, press the contacts together by hand to give a slight pressure on the blade of the burnisher. When contacts are normally closed the tension of the springs will usually furnish sufficient pressure against the burnisher.

- (3) Rub the burnisher back and forth against the contacts two or three times. When contacts are pitted, additional strokes of the burnisher may be required. Do not use abrasives other than the burnisher blade.
- (4) After cleaning and burnishing operations, check the adjustments of the contact springs.

Section IV. LUBRICATION

96. Recommended Lubricants

The only lubricants recommended for these test sets are:

- a. Oil, lubricating, Signal Corps stock No. 6G-1325 (1 qt can).
- b. Grease, Signal Corps stock No. 6G650 (1 lb container).

97. Recommended Lubrication Schedule

The lubrication instructions listed in paragraph 100 are based on normal operating conditions with the equipment in service for an average of 8 hours a day. Under these conditions, the lubrication interval should be every 30 days with the exception of the code disk cam surfaces, which should be lubricated weekly. When equipment is operated more than 8 hours a day, reduce the time interval proportionally. When equipment is operated in tropical climates, a further reduction in the interval is required. Do not lubricate the equipment while the motor is running. Complete all necessary cleaning and adjusting before lubricating the equipment. Do not apply oil or grease in excess of the quantities recommended. Wipe off any excess oil.

98. Preparation for Lubrication

To lubricate the test set thoroughly, remove it from service and partially disassemble it as out-lined in a below.

a. *Disassembly.* Disassemble the test set as follows:

- (1) Disconnect the ac and dc power cords and the signal line cord.
- (2) Remove the wooden cover.

b. *Old Lubricants.* Remove all old grease and oil with a clean, dry, lint-free cloth. Wrap the cloth around the end of a screwdriver or an orange stick to remove old lubricants from hard-to-reach places.

99. General Lubrication Instructions

a. *Methods of Applying Grease.* Use the grease gun supplied with Tool Equipment TE-50-B to apply grease. To grease the gears, hold the nozzle of the grease gun against the gear teeth at an angle of about 45°. Operate the handle until enough grease is ejected and, at the same time, turn the gear or move the nozzle to form a continuous ribbon of grease.

b. *Methods of Applying Oil.* Apply oil with the oiler furnished with Tool Equipment TE-50-B or with a piece of wire approximately .025 inch in diameter. Dip the wire one-half inch into the oil. Withdraw the wire and apply a drop of oil where specified.

100. Detailed Lubrication Instructions (fig. 32)

The points to be lubricated, the type of lubricant to be used, and the quantity to be applied are listed in b below. The item numbers are arranged according to the method of application, so that the test set can be treated by one lubricant or by one method at a time in a systematic way. Item numbers shown in figure 32 correspond with the item numbers listed in the chart below.

a. *Ball Bearings.* To clean and lubricate ball bearing assemblies properly, it is necessary to remove them from the main shaft or the motor armature. Clean the bearing assemblies by brushing and flushing in Cleaning Compound. Thoroughly dry the assemblies and repack them with grease. Wipe off excess grease and reassemble the equipment. The motors in Test Sets TS-2A/TG and TS-2B/TG are equipped with sealed, factory-greased bearings and will not require further, lubrication.

b. *Gears.* Wipe the old grease from the gears with a clean, dry, lint-free cloth. Apply fresh grease as follows:

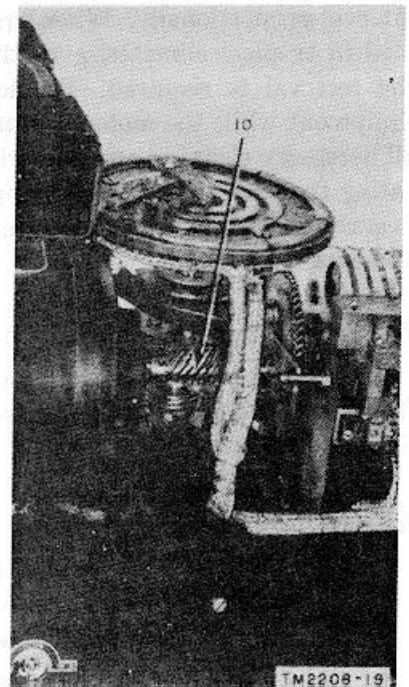
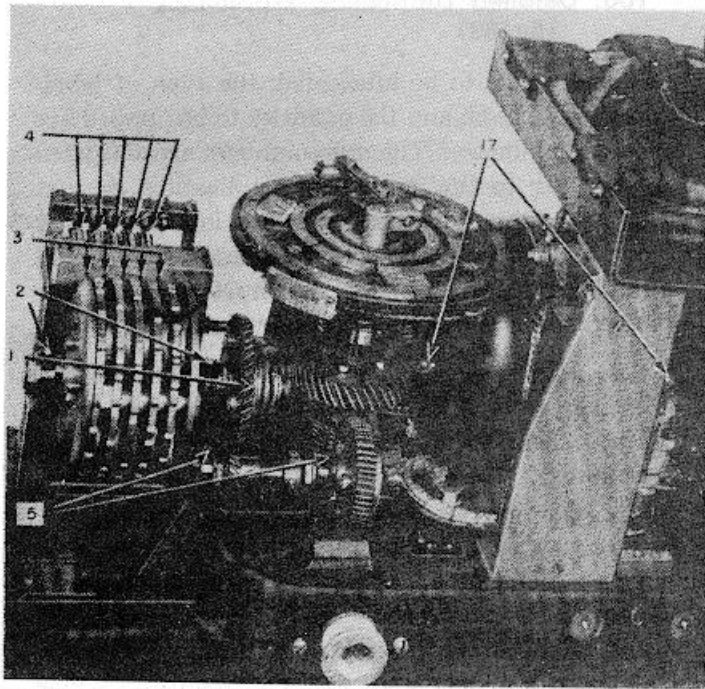
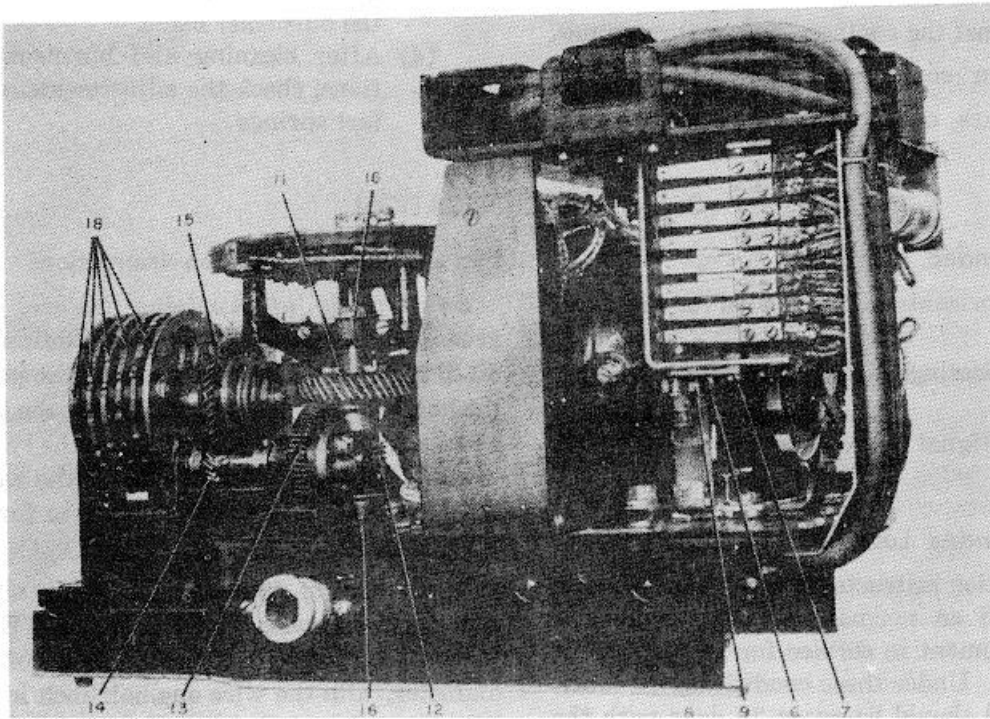

Figure 32. Location of lubricating points.

1	Felt washers, code disk friction assembly	10	Motor pinion gear
2	Code disk shaft bearings	11	Main shaft gear
3	Contact lever bearings and slots	12	Main shaft pinion gear
4	Contact lever pivot bearings	13	Intermediate shaft gear
5	Intermediate shaft bearings	14	Intermediate shaft pinion
6	Detent lever spring	15	Code disk gear
7	Detent lever bearing	16	Main shaft bearings
8	Detent roller	17	Motor bearings
9	Detent cam	18	Code disk cam surfaces

Figure 32-Continued.

Item No.	Name of part	Lubricant	Method and quantity
1	Felt washers, code disk friction assembly.....	Oil	Saturate.
2	Code disk shaft bearings (two) (on TS-2/TG and TS-2A/TG only).	Oil	1 to 2 drops in each oilhole.
3	Contact lever bearings and slots (five).....	Oil	1 drop each slot and bearing.
4	Contact lever pivot bearings (five)	Oil	1 drop each pivot.
5	Intermediate shaft bearings (two) (on TS-2/TG and TS-2A/TG only).	Oil	1 to 2 drops in each oilhole.
6	Detent lever spring	Oil	1 drop to each loon.
7	Detent lever bearing	Oil	1 drop.
8	Detent roller	Grease	Thin film.
9	Detent cam	Grease	Thin film.
10	Motor pinion gear.....	Grease	Thin film.
11	Main shaft gear.....	Grease	Thin film.
12	Main shaft pinion gear.....	Grease	Thin film.
13	Intermediate shaft gear.....	Grease	Thin film.
14	Intermediate shaft pinion.....	Grease	Thin film.
15	Code disk gear.....	Grease	Thin film.
16	Main shaft bearings.....	Grease	Repack and wipe off excess grease.
17	Motor bearings.....	Grease	1 or 2 strokes of grease gun plunger to each oiler.
18	Code disk cam surfaces.....	Grease	Thin film.

Section V. WEATHERPROOFING

101. Weatherproofing Procedures

Test Sets TS-2(*)/TG have been moistureproofed and fungiproofed at the time of manufacture. Retreatment may be required after a period of use. During overhaul of the equipment, moistureproof and fungiproof the equipment in accordance with current directives.

102. Rustproofing and Painting

a. If the finish on painted portions of the test set or wooden cover is scratched or scarred, prevent rust and corrosion by painting the damaged surfaces. Use No. 00 or No. 000 sandpaper to clean the surfaces. Obtain a bright, smooth finish. Do not use steel wool when working on the test set because very small particles of steel wool may enter the electrical parts and cause internal shorting and grounding of circuits.

b. When retouching is necessary, apply the paint with a small brush. If numerous scars and scratches warrant complete repainting, remove the test set from service. Remove slight rust or corrosion from metal by cleaning with Cleaning Compound to soften the rust, then sandpaper to complete the preparation for painting. Place protective masking over areas that do not require paint or where paint may cause damage; then spray-paint the entire surface.

Section VI. FINAL TESTING

103. Purpose

Equipment that has been repaired must meet definite minimum performance standards before it is returned to service. The tests outlined in this section are designed to measure the performance capability of a repaired test set. Equipment that meets the minimum standards stated in the tests will furnish satisfactory operation.

104. Test Equipment Required for Final Testing

In addition to the test equipment listed in paragraph 32, Distortion Test Set TS-383/GG (fig. 33) is required for final testing.

105. Test Setup

Distortion Test Set TS-383/GG is designed to receive and analyze distortion in the signals transmitted by teletypewriter equipment. When performing any tests on Test Sets TS-2 (*) /TG, it is preferable to use synchronous motors on both test sets because an accurate check of the calibration adjustment cannot be made with the variation in speed caused by governed motors. Any speed variation will cause a wavering of the impulses as viewed on the stroboscope, making it difficult to measure accurately the impulse length.

- a. Connect the ac motor power cord of the TS-383/GG into a suitable 110- to 115-volt, 50- to 60-cycle ac source.
- b. Plug the stroboscope cord into one of the LOCAL TEST JACKS of the test set.
- c. Plug the signal line cord of the TS-2 (*) /TG into the other LOCAL TEST JACK. This provides a source of dc for the signal and for the stroboscope lamp.
- d. Plug the ac power cord of the TS-2 (*) /TG into a source of 110- to 115-volt, 50- to 60-cycle ac.
- e. Plug the dc power cord of the TS-2(*)/TG into a source of 115-volt dc.
- f. Place the radio filter cutout switch on the test set in the FILTER OUT position during the time that the test set is being checked.
- g. Place the keys and switches on the TS-383/ GG in the following positions:

MOTOR switch.....	ON
RUN-STOP switch	RUN
LINE-DIST key	LINE
BIAS-END DIST key	Neutral
VIEW-TRANSMIT key.....	TRANSMIT
MARK-ZERO-SPACE key.....	ZERO
Code selecting switch.....	R or Y
STOP PULSE switch.....	ON

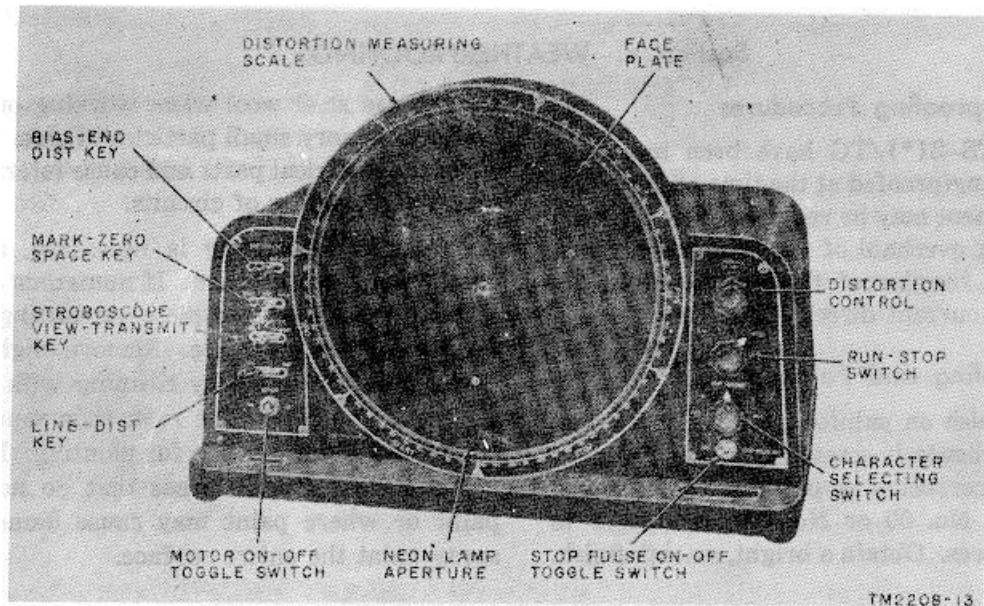

Figure 38. Distortion Test Set TS-383/GG.

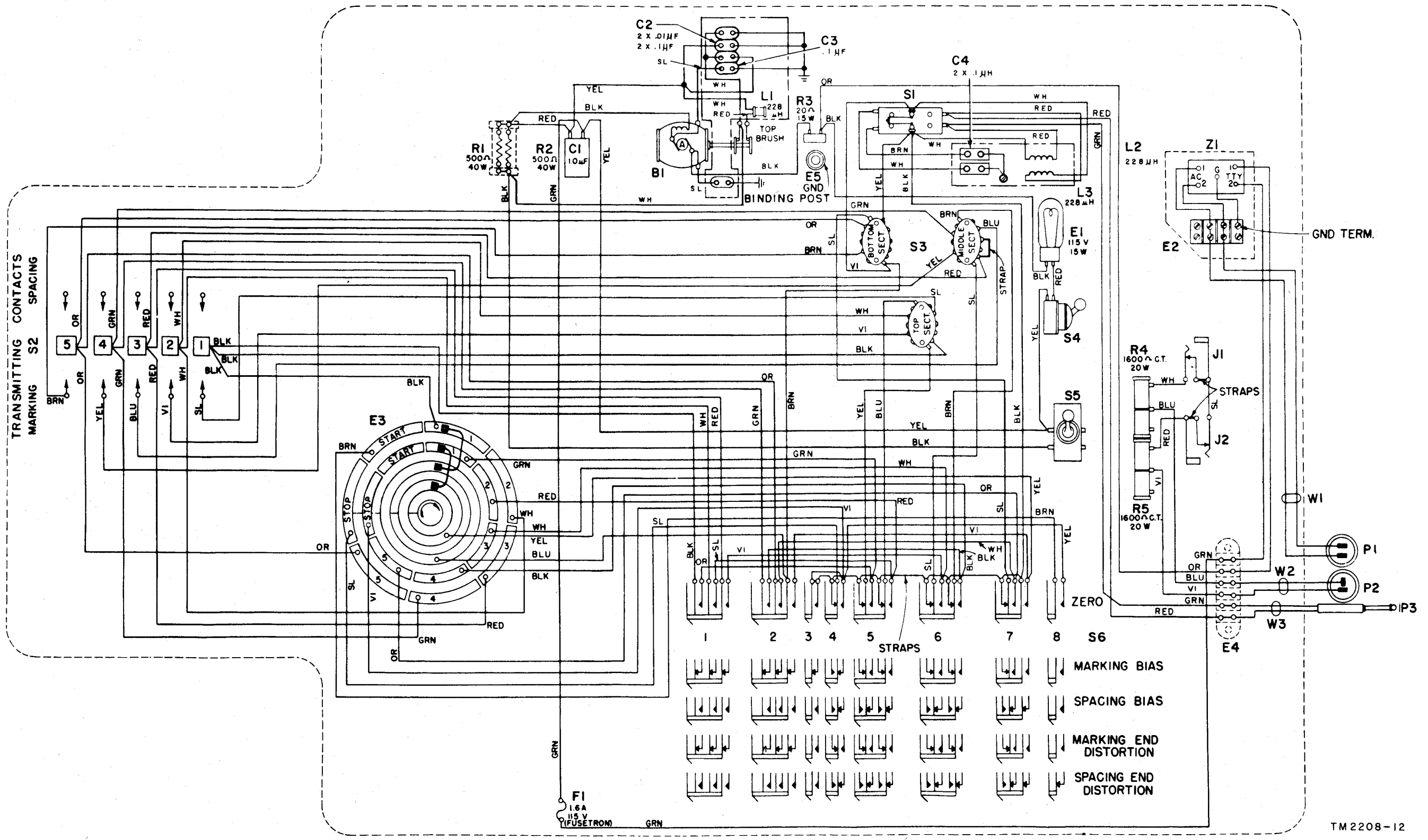

Figure 34. Test Sets TS-2/TG and TS-2A/TG, wiring diagram.

- h.* On the TS-2(*)/TG, set the distortion switch to ZERO and the character selecting switch to STOP.
- i.* Turn the motor switches of both test sets to MOTOR ON.
- j.* Move the character selecting switch on the TS-2(*)/TG to the SEND R position and observe the signal produced on the stroboscope of the TS-383/GG. The marking impulses (2 and 4) should occupy 100 scale divisions on the distortion measuring scale of the TS-383/GG.
- k.* Move the character selecting switch on the TS-2 (*)/TG to the SEND Y position and observe the signal produced on the stroboscope of the TS383/GG. The marking impulses (1, 3, and 5) should occupy 100 scale divisions on the distortion measuring scale of the TS-383/GG.
- l.* If the marking impulses observed in j and k above are more or less than 100 points in length recheck the motor speed adjustment (par. 12) the contact bracket assembly (par. 47) and the contact levers spring tension (par. 48).

CHAPTER 7

SHIPMENT AND LIMITED STORAGE AND DEMOLITION TO PREVENT ENEMY USE

Section I. SHIPMENT AND LIMITED STORAGE

106. Disassembly

Prepare these test sets for storage as follows:

- a. Disconnect the signal and power cords of the test set.
- b. Coil the cords under the retaining brackets on the operating panel.
- c. Close and latch the hinged lid.
- d. Be sure that the cover is in place and is securely latched.

107. Repacking for Shipment and Limited Storage

a. If the original packing materials are on hand, use them and reverse the unpacking procedures given in paragraph 8. General repacking information is usually available at depots.

b. The prime requirement is to pack the equipment so as to prevent damage during transit or limited storage. Package the equipment securely and use sufficient wadding to minimize the effects of severe jolting. Make sure that the equipment is protected from rain or snow.

108. General

Demolition of the equipment will be accomplished only upon the order of the commander. The demolition procedures outlined in paragraph 109 will be used to prevent the enemy from using or salvaging the equipment.

109. Demolition

a. *Smash.* Smash the test set and all other parts; use sledges, crowbars, axes, handaxes, pickaxes, hammers, or heavy tools.

b. *Cut.* Cut all cords and wiring; use axes, handaxes, or machetes.

c. *Burn.* Burn technical manuals, circuit labels, other diagrams, resistors, coils, capacitors, cords, and wiring; use gasoline, kerosene, oil, flame throwers, or incendiary grenades.

d. *Explode.* If explosives are necessary, use firearms, grenades, or TNT.

e. *Dispose.* Bury, scatter, and destroy parts in slit trenches, foxholes, or throw them in streams.

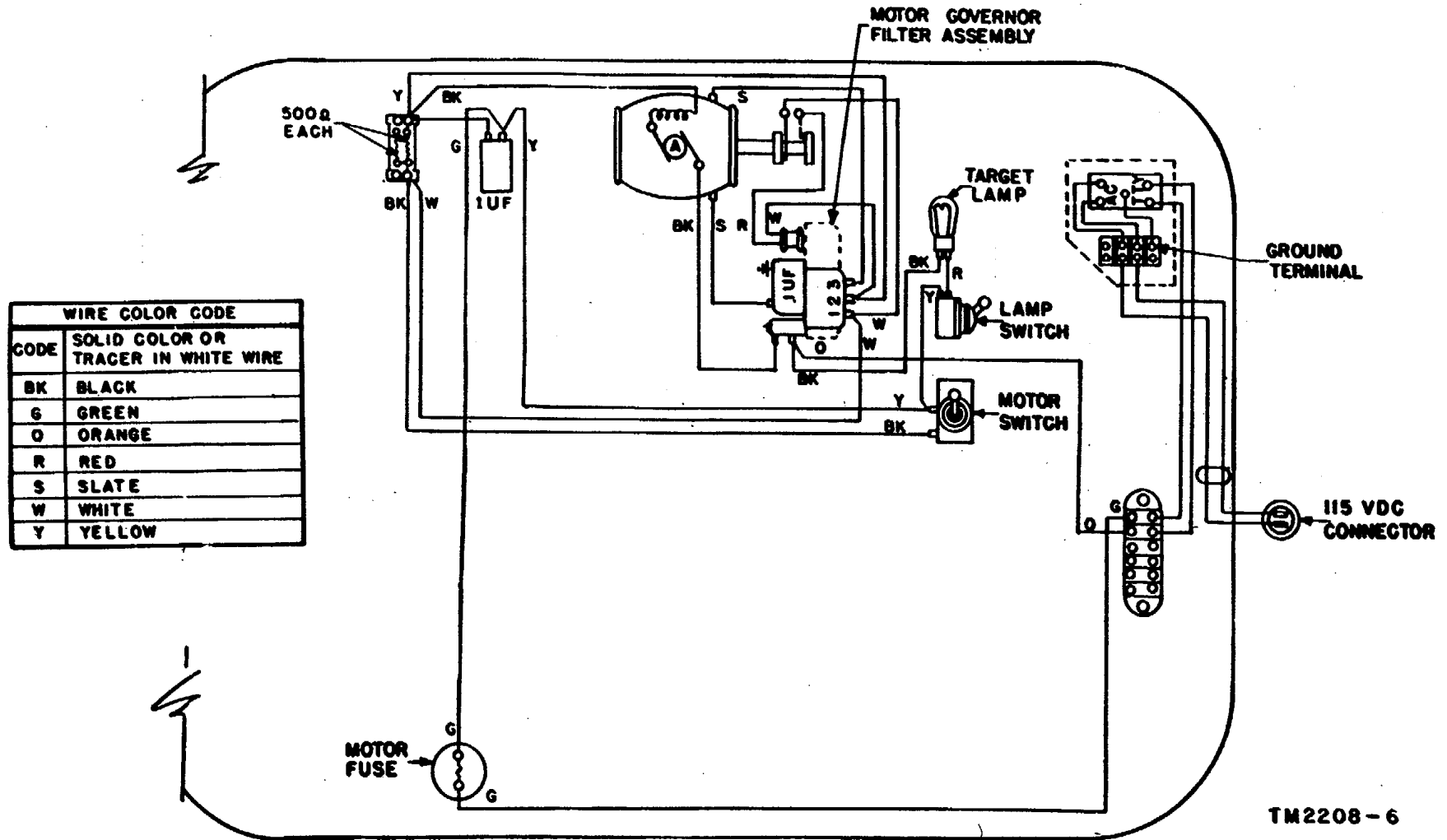

Figure 35. Test Set TS-2A/TG, wiring diagram for motor connections.

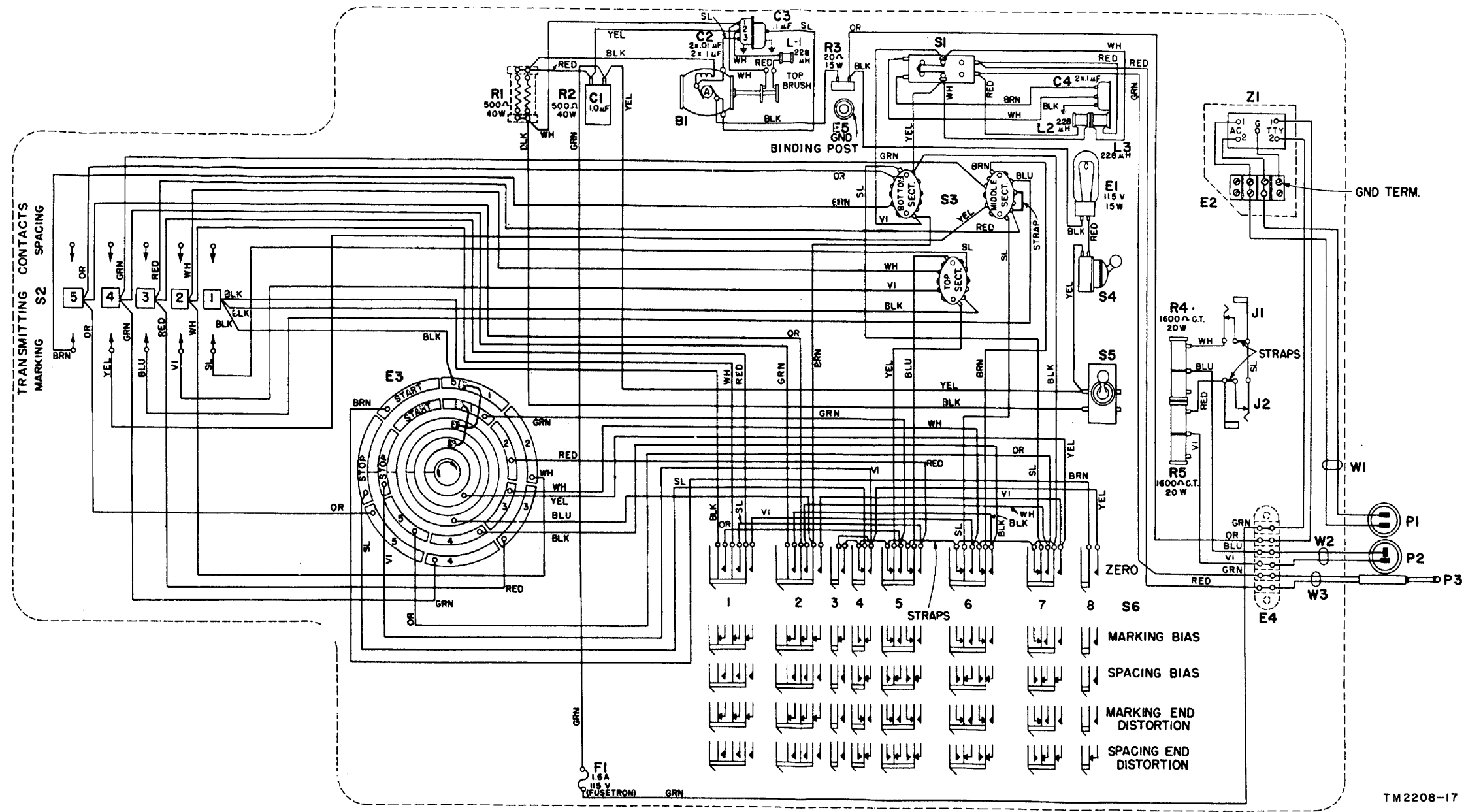

Figure 36. Test Set TS-2B/TG, wiring diagram.

INDEX

	Paragraph	Page		Paragraph	Page
Adjustments:			Code disk shaft gear adjustment.....	46	23
Code disk friction assembly torque.....	52	26	Code disk transmitter assembly.....	60	29
Code disk position.....	51	26	Contact bracket assembly adjustment.....	47	23
Code disk shaft end play.....	43	23	Contact levers spring tension adjustment.....	48	24
Code disk shaft gear.....	46	23	Controls:		
Contact bracket assembly.....	47	23	Controls	18	14
Contact levers spring tension.....	48	24	General.....	17	14
Detent lever.....	54	26	Control mechanisms:		
Distributor brush	49	24	Character selecting switch.....	61	31
Distributor brush spring tension.....	50	25	Distortion switch	62	32
Distortion switch and detent cam.....	53	26	Motor governor.....	63	34
General.....	35	21	Demolition.....	109	54
Governor brush spring plate bracket.....	41	22	Description and data:		
Governor brush spring pressure	42	23	Description.....	5	4
Governor inner and outer disk contact springs.	40	22	Differences in models.....	6	4
Governor shell.....	38	21	Purpose and use.....	3	3
Governor speed adjusting wheel.....	39	21	Detail lubrication instructions	100	49
friction washer.			Detent lever.....	54	26
Intermediate shaft bakelite gear.....	45	23	Disassembly and reassembly of distortion switch.	94	48
Intermediate shaft end play.....	44	23	Disassembly of governor.....	86	44
Main shaft position	36	21	Disassembly of motors for repairs.....	76	40
Motor position.....	37	21	Disassembly, shipment and limited storage.	106	54
Switch contact assembly.....	57	27	Distortion settings	13	9
Switch contact cam.....	55	27	Distortion switch and detent cam.....	53	26
Switch detent lever spring tension.....	56	27	Distortion switch, theory.....	62	32
Armature:			Distributor brush adjustment.....	49	24
Bearings, replacement.....	82	42	Distributor brush spring tension.....	50	25
Replacement or repair.....	78	40	Distributor, theory.....	59	29
Thrust spring compression	84	44	Final testing:		
Undercutting commutator bar.....	79	41	Purpose.....	103	52
separators (insulators).			Test equipment required.....	104	52
Bearings:			Test set-up	105	52
Code disk.....	71	38	First echelon maintenance:		
Main shaft.....	74	39	Materials	27	17
Motor armature.....	82	42	Preventive maintenance.....	28	17
Brushes:			Scope.....	26	17
Distributor	49	24	Use of operators preventive maintenance form.	30	17
Distributor brush spring tension.....	50	25	Visual inspection	29	17
Inner and outer disk contact.....	91	47	Forms and records.....	2	3
Motor, replacement	80	41	Fuse check	10	8
Surfacing and installing.....	81	41	General:		
Changing operating speed.....	16	13	Forms and records	2	3
Checking.....	9	6	Scope.....	1	3
Character selecting switch	61	31	General lubrication instructions.....	99	49
Characteristics, technical	4	3	General troubleshooting techniques:		
Cleaning procedures for major overhaul.....	73	39	General	64	35
Cleaning transmitting and distortion switch contacts.	95	48	Localizing electrical troubles	65	35
Code disk friction assembly torque.....	52	26	Localizing mechanical troubles.....	66	36
Code disk position.....	51	26	Troubleshooting charts	67	36
Code disk shaft end play adjustment.....	43	23			

AGO 3686A

	Paragraph	Page		Paragraph	Page
Governor repairs	85	44	Preliminary starting procedures	19	14
Governor shell adjustment	38	21	Preparation for lubrication	98	49
Governor brush spring plate bracket	41	22	Preventive maintenance:		
Governor brush spring pressure	42	23	First echelon	28	17
Governor inner and outer disk contact springs.	40	22	Second echelon	34	19
Governor speed adjusting wheel friction washer adj.	39	21	Preventive maintenance forms, use:		
Inspection cleaning and repair of governor contact disks.	90	46	Operators	30	17
Intermediate shaft bakelite gear	45	23	Second echelon	34	19
Intermediate shaft end play adjustment	44	23	Purpose, final testing	103	52
Localizing electrical troubles	65	35	Purpose and use	3	3
Localizing mechanical troubles	66	36	Reassembling governor	89	46
Lubrication:			Reassembly of motor	83	43
Detailed lubrication instructions	100	49	Recommended lubricants	96	49
General lubrication instructions	99	49	Recommended lubrication schedule	97	49
Preparation for lubrication	98	49	Refinishing distributor disk	75	39
Recommended lubricants	96	49	Removal and replacement:		
Recommended lubrication schedule	97	49	Character selecting switch	72	38
Main shaft repairs	74	39	Code disk bearing	71	38
Main shaft position adjustment	36	21	Contact lever bracket	71	38
Maintenance forms:			Intermediate shaft assemblies	71	38
First echelon	30	17	Main shaft	70	38
Second echelon	34	19	Motor	69	38
Maintenance, preventive:			Repairs:		
First echelon	28	17	Contact brushes, inner and outer disk	91	47
Second echelon	33	19	Contact lever bracket, disassembly and reassembly.	93	47
Materials, first echelon maintenance	27	17	Contact points	88	46
Materials, tools and test equipment	32	19	Distortion switch, disassembly and reassembly.	94	48
Models, differences	6	4	Governor	85	44
Motor armature, replacement or repairs.	78	40	Governor contact disks	90	46
Motor armature thrust spring compression.	84	44	Governor, disassembly	86	44
Motor brushes, replacing	80	41	Governor reassembly	89	46
Motor brush, surfacing and installing	81	41	Main shaft	74	39
Motor commutators, undercutting bar separators (insulators).	79	41	Major overhaul, cleaning procedure	73	39
Motor, disassembly for repairs	76	40	Motor armature	78	40
Motor governor	63	34	Motor armature thrust spring compression.	84	44
Motor position adjustment	37	21	Motor brushes, surfacing and in-stalling.	81	41
Motor reassembly	83	43	Motors, disassembly	76	40
Motor, special cleaning instructions	77	40	Motors, reassembly	83	43
Motor speed	12	9	Motor, special cleaning instructions	77	40
Operation under normal conditions:			Refinishing distributor disk	75	39
Preliminary starting procedures	19	14	Replacing armature bearings	82	42
Stopping procedure	21	15	Replacing governor contact points	87	45
Types of operation	20	14	Replacing motor brushes	80	41
Operation under unusual conditions:			Testing repaired governors	92	47
Arctic climates	23	16	Transmitting and distortion switch contacts, cleaning.	95	48
Desert climates	25	16	Repacking for shipment and limited storage.	107	54
General	22	15	Replacement of inner and outer disk contact brushes.	91	47
Tropical climates	24	16	Replacement or repair of motor armature	78	40
Power connections	15	9	Replacing armature bearings	82	42
Preinstallation services:			Replacing governor contact points	87	45
Distortion settings	13	9	Replacing motor brushes	80	41
Fuse check	10	8	Rustproofing and painting	102	51
Motor speed	12	9			
Preparation	11	8			

	Paragraph	Page		Paragraph	Page
Scope	1	3	Technical characteristics . . .	4	3
Second echelon maintenance:			Testing, final:		
Preventive maintenance	33	19	Purpose	103	52
Scope.....	31	19	Test equipment required	104	52
Tools, materials and test equipment..	32	19	Test set-up	105	52
Use of second echelon preventive maintenance form.	34	19	Testing repaired governors	92	47
Service on receipt of equipment:			Theory of test sets:		
Checking	9	6	Code disk transmitter assembly	60	29
Siting.....	7	6	Distributor	59	29
Unpacking.....	8	6	General	58	29
Shipment and limited storage:			Troubleshooting techniques:		
Disassembly.....	106	54	General	64	35
Repacking	107	54	Localizing electrical troubles	65	35
Signal connections:			Localizing mechanical troubles	66	36
Changing operating speed	16	13	Troubleshooting chart	67	36
General.....	14	9	Types of operation	20	14
Power connections	15	9	Unpacking	8	6
Stopping procedure.....	21	15	Visual inspection	29	17
Switch contact assembly.....	57	27	Weatherproofing:		
Switch contact cam.....	55	27	Rustproofing and painting	102	51
Switch detent lever spring tension	56	27	Weatherproofing procedures	101	51

[AG 413.6 (5 Dec 56)]

By Order of *Wilber M. Brucker*, Secretary of the Army :

MAXWELL D. TAYLOR,
General, United States Army,
Chief of Staff.

Official:

HERBERT M. JONES,
Major General, United States Army,
The Adjutant General.

Distribution:

Active Army:

CNGB (1)	Sig Lab (5)
ASA (3)	ACS (3)
Tec Svc, DA (1) except CSIGO (30)	Mil Dist (1)
Tec Svc Bd (1)	Units org under fol TOE:
Hq CONARC (5)	9-7R (2)
CONARC Bd (Incl ea Test Sec) (1)	11-7C (2)
Army AA Comd (2)	11-15C (2)
OS Maj Comd (5)	11-16C (2)
OS Base Comd (5)	11-17C (2)
Log Comd (5)	11-18C (2)
MDW (1)	11-57C (2)
Armies (5)	11-95R (2)
Corps (2)	11-96R (2)
Div (2)	11-97R (2)
Ft & Cp (2)	11-98R (2)
Sp Wpn Comd (2)	11-117R (2)
Army Cml Cen (4)	11-127R (2)
Gen & Br Svc Sch (5) except Sig Sch (25)	11-128C (2)
except Sig Sch Ft Monmouth (215)	11-500R (2)
Gen Depots (2) except Atlanta Gen Depot	11-537R (2)
(None)	11-557C (2)
Sig Sec, Gen Depots (10)	11-587R (2)
Sig Depots (17)	11-592R (2)
US Army Tng Cen (2)	11-597R (2)
POE (OS) (2)	20-300R (2)
Trans Terminal Comd (2)	32-51R (2)
Army Terminals (2)	32-55R (2)
OS Sup Agencies (2)	32-56R (2)
Army Elct PG (1)	32-57R (2)
Sig Fld Maint Shops (3)	32-500R (2)

NG: State AG (6) ; units—same as Active Army except allowance is one copy to each unit.

USAR: None.

For explanation of abbreviations used, see SR 320-50-1.

★ U.S. GOVERNMENT PRINTING OFFICE : 1987 O - 201-421 (70939)

AGO 3686A

RECOMMENDED CHANGES TO EQUIPMENT TECHNICAL PUBLICATIONS



*THEN...JOT DOWN THE
DOPE ABOUT IT ON THIS FORM.
CAREFULLY TEAR IT OUT, FOLD IT
AND DROP IT IN THE MAIL.*

SOMETHING WRONG WITH PUBLICATION

FROM: (PRINT YOUR UNIT'S COMPLETE ADDRESS)

DATE SENT

PUBLICATION NUMBER

PUBLICATION DATE

PUBLICATION TITLE

BE EXACT PIN-POINT WHERE IT IS

PAGE
NO.

PARA-
GRAPH

FIGURE
NO.

TABLE
NO.

**IN THIS SPACE, TELL WHAT IS WRONG
AND WHAT SHOULD BE DONE ABOUT IT.**

PRINTED NAME, GRADE OR TITLE AND TELEPHONE NUMBER

SIGN HERE

